

**STATE OF NEW YORK
WORKERS' COMPENSATION BOARD**

**MEDICAL
GUIDELINES**

June 1996

TABLE OF CONTENTS

FOREWORD	vii
INTRODUCTION	1
A. ROLE OF EXAMINING HEALTH PROVIDERS	2
B. ROLE OF THE WORKERS' COMPENSATION LAW JUDGE	2
C. DISABILITY EVALUATION IN WORKERS' COMPENSATION CASES.....	2
Review of the Claimant's File	3
1. TYPES OF DISABILITY UNDER THE WORKERS' COMPENSATION LAW	3
2. TYPES OF FINAL EVALUATION EXAMINATION	3
Schedule Awards	4
Non-Schedule Awards	5
I. EXTREMITIES	6
A. UPPER EXTREMITIES	6
1. THUMB	6
2. FINGERS	8
Special Considerations	8
3 . BONE LOSS	9
4. LOADING	9
5. AMPUTATIONS	10
6. DUPUYTREN' S CONTRACTURE	10
7. WRIST	11
Special Considerations	12

8. ELBOW	13
Special Considerations	14
9. SHOULDER JOINT	14
Special Considerations	15
B. LOWER EXTREMITY	16
1. HIP	16
Special Considerations.	16
2. KNEE.	17
Special Considerations.	18
3. ANKLE AND FOOT.	19
Special Considerations	21
4. GREAT TOE	21
Amputations	21
Defects of Mobility	21
5. SMALLER TOES (SECOND, THIRD, FOURTH & FIFTH)	22
Special Considerations (Loading)	22
II. LOW BACK.	23
A. EXAMINATION PROCESS	23
1. HISTORY	23
2. PRESENT COMPLAINT	23
3. PHYSICAL EXAMINATION	23
B. DIAGNOSTIC PROCEDURES AND SPECIALIZED TESTS	25
C. DIAGNOSTIC FINDINGS.	25
D. OTHER IMPORTANT POSITIVE LABORATORY FINDINGS	25
E. MODALITIES OF TREATMENT.	25

F. CRITERIA THAT MAY BE USED FOR EVALUATION OF DEGREE OF PARTIAL DISABILITY	26
Mild	26
Moderate	26
Marked	27
G. DETERMINATION OF TOTAL DISABILITY	27
H. FINAL ASSESSMENT OF LOW BACK EXAMINATION	27
I. CONCLUSION OF CAUSALLY RELATED SPINAL INJURIES (NECK AND LOW BACK)	28
III. CERVICAL SPINE INJURIES DUE TO TRAUMA	29
A. PATHOPHYSIOLOGY	29
B. EXAMINATION PROCESS	30
1. HISTORY	30
2. PRESENT COMPLAINT	30
3. PHYSICAL EXAMINATION	30
C. DIAGNOSTIC TESTING AND INTERPRETATION OF FINDINGS	30
D. TREATMENT.	31
E. FINAL ASSESSMENT OF DISABILITY OF THE CERVICAL SPINE	31
IV. NERVOUS SYSTEM	32
CENTRAL NERVOUS SYSTEM	32
A. CRANIOCEREBRAL TRAUMA	32
B. SEQUELAE	32
C. CRANIAL NERVES	33
1. First Nerve	33
2. Third, Fourth, & Sixth Nerve	33
3. Fifth Nerve	33

4. Seventh Nerve	33
5. Eighth Nerve	33
6. Ninth, Tenth and Eleventh Nerve	33
7. Twelfth Nerve	33
D. MOTOR SYSTEM DEFECTS	34
1. Cortex	34
2. Spinal Cord	34
E. SENSORY DEFECTS	35
F. CONCLUSIONS	35
G. PLEXOPATHIES	36
H. THORACIC OUTLET SYNDROME	37
I. ENTRAPMENT NEUROPATHIES	37
J. MEDIAN NERVE - (CARPAL TUNNEL SYNDROME)	37
K. ULNAR - (CUBITAL TUNNEL SYNDROME)	38
1. Elbow	38
2. Wrist	38
L. ANTERIOR INTEROSSEOUS (PRONATOR TERES SYNDROME)	38
L. (A) POSTERIOR INTEROSSEOUS	39
M. LATERAL FEMORAL CUTANEOUS NERVE (MERALGIA PARESTHETICA)	39
N. TARSAL TUNNEL SYNDROME (POSTERIOR TIBIAL ENTRAPMENT)	40
O. PLANTAR (MORTON'S METATARSALGIA)	40
P. COMPLICATIONS OF PLEXUS AND PERIPHERAL NERVE INJURY	40
Q. CAUSALGIA	40
V. LESS COMMON WORK RELATED CONDITIONS AND DISORDERS	42

A. MEDICAL DISORDERS	42
1. WORK RELATED DERMATITIS	42
2. CAUSALLY RELATED INFECTIOUS DISEASES	42
3. WORK RELATED POST TRAUMATIC NEUROSIIS; POST TRAUMATIC STRESS DISORDER AND OTHER CAUSALLY RELATED PSYCHIATRIC CONDITIONS	42
B. SURGICAL DISORDERS	42
1. HERNIA	42
2. CAUSALLY RELATED SURGICAL EXCISION OF VITAL ORGANS	43
3. FACIAL SCARS AND DISFIGUREMENT	43
VI. RESPIRATORY DISEASES, CARDIOVASCULAR DISEASES AND VASCULAR DISEASES OF THE EXTREMITIES	44
A. EVALUATION PROCESS	44
B. RESPIRATORY DISEASES	45
1. HISTORY	45
2. CLINICAL EVALUATION	45
3. PHYSICAL EXAMINATION	45
4. DIAGNOSTIC TESTING	45
5. CRITERIA FOR EVALUATING DEGREE OF DISABILITY AS RELATED TO RESPIRATORY DISEASES	46
Permanent Partial Disability	46
Permanent Total Disability	47
C. CARDIOVASCULAR DISEASES	47
1. MEDICAL EVALUATION OF CARDIOVASCULAR CASES	47

2. EVALUATION CRITERIA FOR CARDIOVASCULAR DISEASES	48
Permanent Partial Disability	48
Mild	48
Moderate	48
Marked	48
Permanent Total Disability	49
D. VASCULAR DISEASES OF THE EXTREMITIES	49
VII. VISUAL SYSTEM	50
A. CRITERIA AND METHODS FOR EVALUATING PERMANENT IMPAIRMENT	50
1. CENTRAL VISUAL ACUITY	50
2. VISUAL FIELDS	51
3. DETERMINING LOSS OF VISUAL FIELD	51
4. DETERMINING SCHEDULE FOR DIPLOPIA	52
VIII. LOSS OF HEARING	53
A. OCCUPATIONAL LOSS OF HEARING	53
B. TRAUMATIC LOSS OF HEARING	53
APPENDIX I - REFERENCES	54
APPENDIX II - TABLES	55
Table of Weeks by Percentage Loss of Use of Body Parts	55

FOREWORD

In 1983, the New York State Legislature established a Temporary State Commission on Workers' Compensation and Disability Benefits to study and evaluate the systems of the New York State Workers' Compensation Board. Appointments to the twelve-member Commission in 1984 included representatives of organized labor, the insurance industry, the business community and the public-at-large. In addition, the Commissioner of Labor, the Superintendent of Insurance, and the Chair of the Workers' Compensation Board were designated as ex officio members.

In 1986, the Commission issued its final recommendations, among which was the establishment of published uniform medical guidelines for the evaluation of functional impairments. Such guidelines would be available to the public in general, and to medical and legal practitioners in particular.

The utilization of guidelines should result in a more uniform evaluation process and greater consistency among providers in making functional impairment determinations, ultimately leading to a lesser amount of litigation with regard to such evaluations.

In order to meet this mandate, a committee was formed, co-chaired by the Workers' Compensation Board Medical Director and the Director of Regulatory Services, including representatives of the medical profession and insurance industry. Utilizing all available sources of information, including the American Medical Association's guides of the Evaluation of Permanent Impairment, the committee produced the document which follows.

These guidelines are effective immediately.

INTRODUCTION

Prior to the creation of the current New York State workers' compensation system, when a worker was injured, the only remedy was to sue in a court of law. In these instances the employer usually raised one of three objections -- that the worker had assumed the risk of employment, that the injury was caused by the worker's negligence, or that the injury was caused by the negligence of a fellow worker. In addition, because of crowded court calendars, years frequently passed before a decision was rendered. Consequently, it was quite difficult for injured workers to receive adequate and timely compensation for their injuries.

In 1909, the New York State Legislature created the Wainwright Commission to "inquire into the working of a law in the State of New York relative to the liability of employer to employees for industrial accidents...and to the causes of accidents to employees." The Commission proposed legislation fixing liability upon an employer regardless of fault or negligence.

The Legislature enacted these proposals in 1910, but the compulsory aspect of the law was declared unconstitutional by the New York Court of Appeals. However, due in part to the fire at the Triangle Shirtwaist Company in New York City in March, 1911, which killed 146 factory workers, the Legislature proposed, and the voters adopted, a constitutional amendment permitting the enactment of a compulsory workers' compensation statute.

Enacted in 1914, the New York State Workers' Compensation Act provides the basis for today's workers' compensation system, whereby an injured employee is entitled to all medical care and prompt payment of compensation for lost wages, if the injury arose out of and in the course of employment. The intent is to permit an injured employee to receive wage replacement and complete payment of medical bills without being required to prove which party was at fault.

Weekly indemnity benefits are determined by several factors including the degree of impairment. The degree of impairment is based on medical evidence presented at a workers' compensation hearing by various parties of interest. It is expected that the development of a body of information providing guidelines to the evaluation of both work-related injuries or illnesses leading ultimately to a recommendation as to the degree of disability, will provide for greater equity for all parties as well as expedite the review process.

The medical guidelines which follow were developed in accordance with a recommendation of the Temporary State Commission on Workers' Compensation. It is hoped that they will serve as a convenient reference source for evaluating work-related injuries, and introduce clarity and regularity into the determination of disability.

A. ROLE OF EXAMINING HEALTH PROVIDERS

Health providers are obligated to provide the Board and the parties their best professional opinion based upon the guidelines herein in evaluating the medical condition and the disability, if any, of the compensation claimant.

It is the responsibility of the health provider to submit medical evidence which the Workers' Compensation Law Judge will consider in making a legal determination about disability. When the health provider wishes to comment on non-medical factors such as age, occupation, education, etc., an explanation must be given as to the impact of these factors on the overall evaluation of the medical condition. The impact of such extrinsic factors should generally not be used in determining disability, but should be taken into account by the health provider in making a recommendation as to whether a claimant can perform within his or her regular course of employment and what medical limitations exist. The health provider should provide information as to what the claimant can do, and for how long in a given period, whether public transportation can be taken and any other relevant factors affecting the health provider's opinion as to the nature and degree of disability.

B. ROLE OF THE WORKERS' COMPENSATION LAW JUDGE

The Workers' Compensation Law Judges have the responsibility of deciding, subject to Board review, all of the legal and factual issues which are raised before the New York State Workers' Compensation Board. These judges act in the same manner and with many of the responsibilities as judges of any court of record within this State.

Cases before the Board involve litigation between private parties, such as claimants, their employers and the compensation insurance carriers for those employers; therefore, the Board should be viewed much like a court of limited jurisdiction and the role of our judge

should be viewed in this context. The Law Judges preside at hearings, hear witnesses, rule on evidentiary issues, and issue decisions. The Law Judge may, where appropriate, order a deposition and other forms of discovery.

It is the Workers' Compensation Law Judge who must make all determinations on issues such as disability and degree, classification and/or schedule loss of use. Health care providers, whether they be impartial specialists, treating doctors or carrier consultants, submit reports and make recommendations. These reports and recommendations are part of the evidence to be considered by the Judge in making a final determination on all issues including medical issues. In making such factual and legal determinations, the Workers' Compensation Law Judge takes into account a variety of non-medical factors such as age, education, language skills, etc. which may impact on a claimant's ability to work. It is the responsibility of the Workers' Compensation Law Judge to rule, based upon the evidence presented, and it is the role of the health provider to provide medical evidence and recommendations.

It is against this background that our Law Judges must consider and make the medical findings necessary in each case.

It is important that the Judge in evaluating the medical reports be advised of the basis and criteria used by health providers in reaching their diagnosis and recommendations. The Medical Guidelines provide such a basis and criteria. Thus, these Guidelines are a tool not only for medical providers, but for the WCL Judge as well.

C. DISABILITY EVALUATION IN WORKERS' COMPENSATION CASES

The disposition of work-related claims is a legal process, and decisions are made by a law judge based on available medical evidence. Such evidence may be submitted by a medical

consultant for the employer or the patient's health provider. Reports on the same issues are often contradictory and confusing. Accordingly, the health provider's accuracy and attention to detail, as well as his/her professional standing and credibility in both reports submitted and testimony given at hearings, will carry weight in the judge's determination. The findings of ANCR (Accident, Notice and Causal Relationship) and ODNCR (Occupational Disease Notice Causal Relation) and the part of the body injured in the accident, are made by the judge and these findings alone determine the validity of a claim under the Workers' Compensation Law. The judge must clarify any discrepancies in ANCR and note preexisting impairments; consequential injuries (injuries which occurred later but are attributed to the original injury) must also be recorded and considered in establishing ANCR. Health providers' reports and testimony, therefore, must carefully distinguish pre-existing impairments and consequential injuries from the original causally related injury.

Review of the Claimant's File

In certain situations (e.g., when the claimant cannot be present or has died) the medical records are the only source on which decisions can be made. In reviewing a claimant's file, it is essential to:

1. Identify the claimant.
2. Identify the nature of the injury by the original accident report or a later report.
3. Note previous legal decisions, including ANCR and ODNCR.
4. Note medical reports listing pre-existing impairments, both work related and non work-related.
5. Note hospital records including emergency room records, operative reports, diagnostic workups, reports on tests and X-rays.

6. Note the nature of treatment given, rehabilitation management and outcome.

1. TYPES OF DISABILITY UNDER THE WORKERS' COMPENSATION LAW

The Law establishes the following types of disability in workers' compensation cases:

1. Temporary total disability.
2. Permanent total disability.
3. Partial disability.
4. Permanent partial disability.

All are determined in accordance with the facts of the case; however, in addition, by statute, the loss of both hands, or both arms or both feet, or both legs, or both eyes, or any two thereof, in the absence of conclusive proof to the contrary, will constitute permanent total disability. Mental or physical impairment of bodily systems, such as the respiratory, cardiovascular or nervous system, may also lead to permanent total disability. A distinction is made between disability and impairment. Permanent impairment is a purely medical condition and is defined as any anatomic or functional abnormality or loss remaining after maximal medical rehabilitation has been achieved and which the claimant's health provider considers stable or nonprogressive at the time evaluation is made. Permanent impairment is always a basic consideration in the evaluation of permanent disability, whether total or partial.

2. TYPES OF FINAL EVALUATION EXAMINATION

Competent evaluation of permanent impairment requires an adequate and complete medical examination, accurate objective assessment of function, and avoidance of subjective impressions and non-medical factors, such as

the patient's age, sex, occupation and employment. Unlike disability, permanent impairment can be measured with a reasonable degree of accuracy and uniformity on the basis of impaired function as evidenced by loss of structural integrity, pathology, and pain substantiated by clinical findings.

Examining physicians will conduct final evaluation examinations in connection with the following categories of awards:

1. A schedule award for:
 - a. Impairment of extremities
 - b. Loss of vision
 - c. Loss of hearing
 - d. Facial disfigurement
2. Non-Schedule Award for:
 - a. Continuing partial or total disability
 - b. Classification as permanent partial disability (for purposes of lump sum adjustment).
 - c. Classification as permanent total disability.

Schedule Awards

A schedule award is given not for an injury sustained, but for the residual permanent physical and functional impairments. Final adjustment of a claim by a schedule award must comply with the following medical requirements:

1. There must be a permanent impairment of an extremity (or permanent loss of vision or hearing or permanent facial disfigurement as defined by law).
2. The impairment must involve anatomical or functional loss such as soft tissue, bone, sensation, atrophy, scarring deformity, mobility defects, loss of power, shortening, impaired dexterity or coordination.
3. Treatment must have been terminated and further improvement is not expected.
4. No residual impairments must remain in the systemic area (i.e., head, neck, back, etc.) before the claim is considered suitable for schedule evaluation of an extremity or extremities involved in the same accident.
5. Certain time limits (starting from the date of injury) should be met before a schedule award may be considered: six months for digits, one year for major parts (hands, arms, feet, legs), two years for nerve injuries and special situations such as spine and pelvic fractures with neurological or urological complications. (Please note that these time frames are guidelines only; the time element may be longer or shorter based on the status of the injury). If there are continuing residual impairments resulting in a disability, a classification (see definition below) is in order instead of a schedule.

Workers' Compensation Law Section 15 prescribes the value for a percentage loss or loss of use of body members. See Appendix II for

table containing the appropriate number of weeks of compensation provided by percentage of loss.

Non-Schedule Awards

If the case is not amenable for schedule evaluation, classification is considered. Classification disposes of cases with a continuing or progressive impairment resulting in a disability. The impairment may involve conditions of the head, neck, spinal disc, heart, lungs, abdomen and all non-schedule conditions of the extremities. In general a time interval of two years is observed before classification.

There must be residual impairments which are the basis for the conclusion of a permanent total or permanent partial disability.

Some other factors considered for classification may be age, ability to work, mental attitudes and motivation. A classification is a legal decision made by the Workers' Compensation Law Judge in his/her final determination of a claimant's disability.

Examples of impairments of the extremities not amenable for scheduled evaluation and disposed as classification are:

1. Progressive and severe painful conditions of the major joints of the extremities such as the shoulders, elbows, hips and knees with:
 - a. Objective findings of acute or chronic inflammation of one or more joints such as swelling, effusion, change of color or temperature, tenderness, painful range of motion, etc.
 - b. X-ray evidence of progressive and severe degenerative arthritis.
 - c. Minimal or no improvement after all modalities of medical and surgical treatment have been exhausted.
2. Chronic painful condition of an extremity commonly affecting the distal extremities

such as the hands and feet, with:

- a. Documented diagnosis of reflex sympathetic dystrophy, Sudeck's atrophy or chronic painful extremity syndrome.
 - b. Objective findings of chronic swelling, atrophy, dysesthesias, hypersensitivity or changes of skin color and temperature such as mottling.
 - c. X-ray evidence of osteoporosis.
 - d. Minimal or no reported improvement after claimant has undergone all modalities of chronic pain treatment.
3. Mal-union of the long bones.
 4. Aseptic necrosis of the head of the femur or other bones.
 5. Instability of the knee joint or other major joints.
 6. Advanced Paget's disease.
 7. Tumors.
 8. Caisson's disease involving the joints.
 9. Chronic ulcerations, draining sinuses.
 10. Recurrent dislocations (shoulders).
 11. Amputees with neuromas or poorly healed stumps.
 12. Failed joint replacement such as total hip, total knee and shoulder replacements.

I. EXTREMITIES

Abbreviation codes for the guidelines and practice:

Mi = Mild

Mo = Moderate

Ma = Marked

F = Flexion defect

E = Extension defect

DIP = Distal interphalangeal joint

PIP = Proximal interphalangeal joint

MCP = Metacarpophalangeal joint

CMC = Carpo-metacarpal joint

MTP = Metatarsophalangeal joint

SLU = Schedule loss of use

ANCR = Accident Notice Causal Relation

ODNCR = Occupational Disease Notice Causal Relation

A. UPPER EXTREMITIES

1. THUMB

Percent Loss of Use of the Thumb:
Flexion and Extension

Joints	Mild	Moderate	Marked
IP	10-15%	20-25%	40-45%
MCP	15-20%	25-30%	45-50%
IP & MCP	20-30%	40-50%	80-90%
CMC	20-25%	30-40%	50-90%

Figure 1. Composite Motion of the Thumb

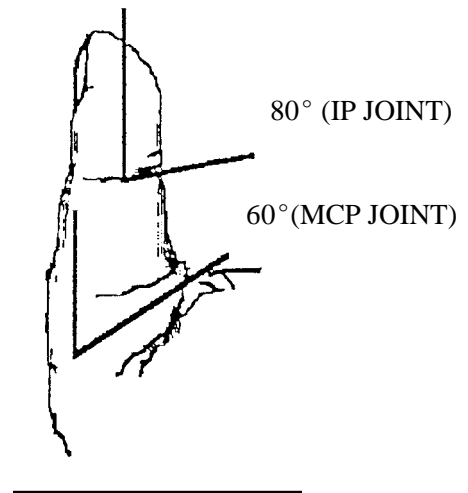

Percent Loss of Use of the Thumb:
Thumb Ankylosis or Loss of Active Flexion

At IP Joint	50%
At MCP Joint	75%
At CMC Joint	80-100%

Figure 1.1 Distal IP Joint

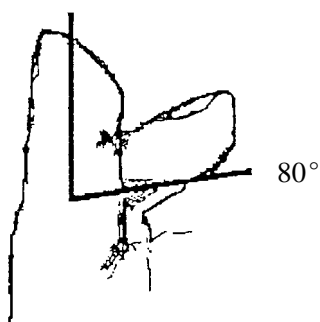
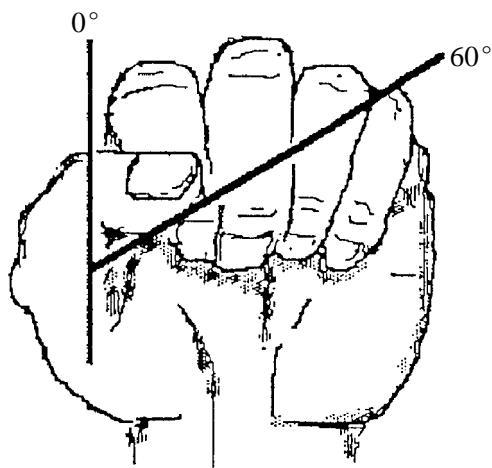

Figure 1.2 MCP Joint



Mild impairment of thumb adduction is equal to 7 1/2% loss of use of the thumb;

radial abduction is equal to 10%; impairment of opposition is 10%. Moderate to marked mobility defects are given a higher schedule.

Figure 2.1 Radial Abduction

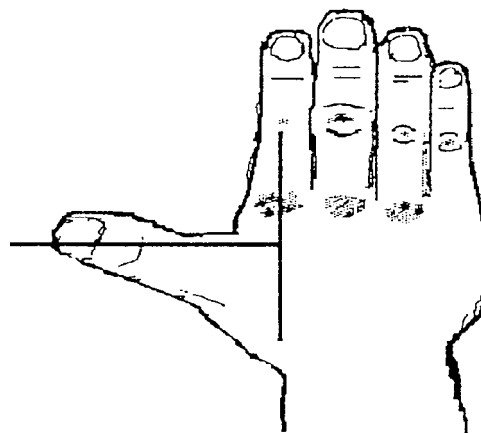
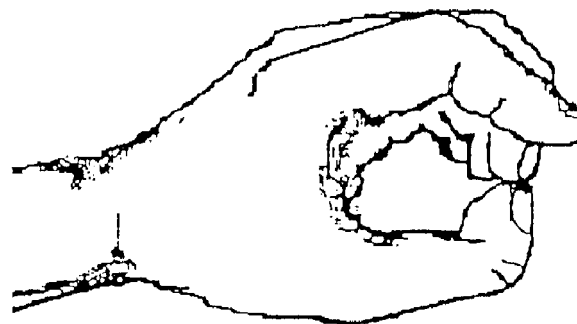

Figure 2.2 Opposition



Cases when a thumb defect becomes a hand schedule:

1. Loss of active flexion or ankylosis at CMC joint is 100% loss of use of the thumb and is usually associated with a wrist defect in which case it becomes a hand schedule.

2. A 100% schedule loss of use of the thumb equals 75 weeks. In cases of amputation above the MCP joint, there is a load of 100% which means an additional 75 weeks. This total of 150 weeks is equal to 60% loss of use of the hand.
3. Abduction and opposition of the thumb is mainly centered on the CMC joint with possible defects at the MCP and IP joints, resulting in mild, moderate or marked impairment of pinch and grasp power of the hand. Such cases are given a hand schedule.

2. FINGERS

Figure 3.1 Range of Motion of DIP Joint

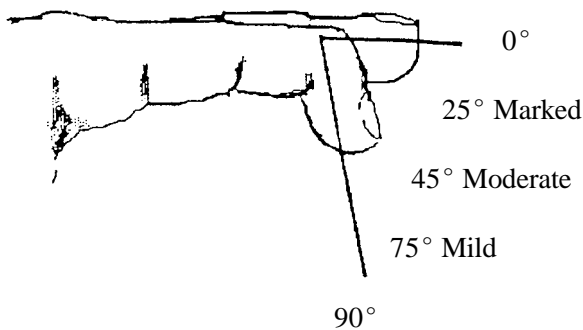
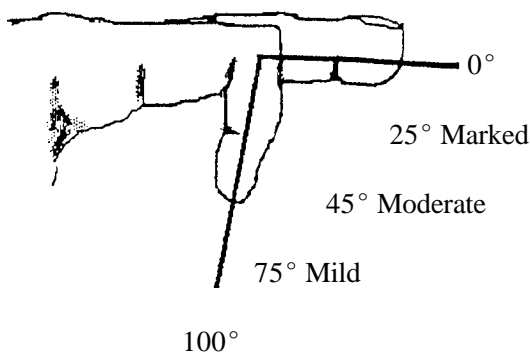

Figure 3.2 Range of Motion of PIP Joint



Percent Loss of Use of the Fingers (index, middle, ring, small): Mobility Defects

Joints	Mild	Moderate	Marked
DIP	10-15%	20-25%	40-45%
PIP	15-20%	25-30%	45-50%
MCP	20-25%	30-40%	50-90%

Joint Values

In order to apply the figures in the chart, if a single motion defect is involved, (flexion or extension) the lower figure applies. If both flexion and extension are involved, the higher figure applies.

Special Considerations

The following are special considerations in the final adjustment of the fingers.

1. Values for losses in all three joints are cumulative: A reduction to the sum of two major values may be in order.
2. Mallet deformity: Up to 33 1/3% loss of finger depending on degree.
3. Trigger finger 25-33 1/3% loss of finger.
4. Loss of half or more of the distal phalanx 50% of finger.
5. Ankylosis of DIP joint: Loss of active flexion: 50% of finger.
6. Flail DIP joint: 50% loss of finger.

3. BONE LOSS

Loss of tip of tuft of the distal phalanx equals 15% to 20% loss of use of the finger. Add percentage for mobility defect at the DIP joint if present.

Loss through the base of the tuft equals 33 1/3% loss of use of the finger.

Loss of half or all of the distal phalanx of the finger equals 50% loss of use of finger (no additional values added for mobility impairment at the DIP joint). Amputation through the DIP joint equals 50% loss of use of the finger.

Loss of any portion of the middle phalanx equals 100% loss of use of the finger.

Loss involving the proximal phalanx equals 100% loss of use of the finger.

Loss involving the entire finger and any part of the ray (metacarpal) equals 100% loss of use of the finger and is loaded 100% and converted to a hand schedule.

Schedules of below 50% in one or two digits remain in the digits. Schedules below 50% loss of use of three digits are loaded 25% and converted to a hand schedule.

Schedules of 50% or more in two or more digits are loaded 50% and converted to a hand schedule.

In cases where 100% was given for a member, additional schedules may be given under certain circumstances, e.g., amputation above the elbow receives 100% schedule loss of the arm. In case of future shoulder injury, additional schedule may be given for the arm.

4. LOADING

This is the amount added to a schedule to allow for weakness of grasp or major loss of function when multiple digits are affected.

In cases of loss of three fingers with less than 50% loss of use in each finger, a hand schedule is given with a 25% load.

Amputation of half of the distal phalanges of two or more digits or ankylosis of the DIP joints of two or more digits and loss of active flexion of two or more digits is loaded 50% and given a hand schedule.

Amputation through the middle phalanges of two or more digits is loaded 50% and given a hand schedule.

Amputation through the proximal phalanges of two or more digits is loaded 100% and given a hand schedule.

The load is 50% when one digit has 100% loss of use and another digit has 50% loss of use. No load is given when one digit has 50% loss of use and another has less than 50% loss of use; instead a separate percentage is given for each finger. The load is 50% when there is a 100% bone loss in either the thumb or index finger and a second digit has less than 50% loss of use.

The thumb deserves special consideration; it is the highest valued digit and the most important. The functional units of the thumb are the proximal and distal phalanges and the first metacarpal. An amputation involving the first metacarpal is loaded 100% and given a hand schedule. This is a major impairment of hand function with loss of pinch and reduced grasping power; furthermore, opportunity for reconstructive surgery is eliminated.

5. AMPUTATIONS

Determination of residual impairment and functional loss depends on the level of amputation. Reliance on initial X-rays or reports may be misleading.

The operative amputation is frequently performed at a higher level in order to obtain adequate closure or better function. If in doubt, new post operative X-rays are needed to determine the degree of bone loss and the final level of amputation. This information will be needed in calculation of schedule loss.

Loss of all fingers at proximal phalanges equals 100% schedule loss of use of the hand.

Figure 4. Schedule Loss of Use of the hand Due to an Amputation.

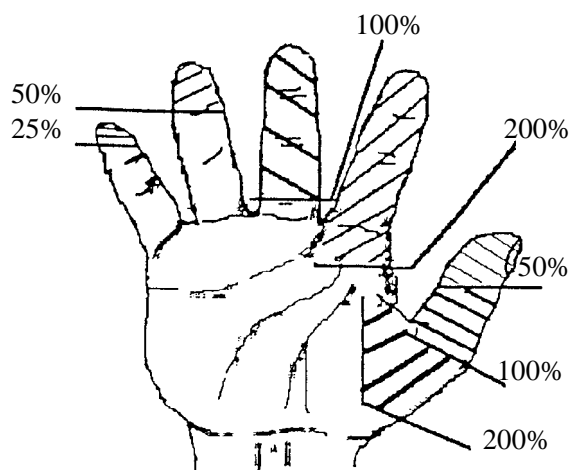

Note: Hand schedules can be verified by the usual

method of calculations.

Percent Loss of the Use of the Hand: Amputation of Two or More Fingers at Different Levels

Fingers	Proximal Phalanx	Middle Phalanx	Distal Phalanx
Thumb & Index	90%	75%	35%
Index & Middle	66 2/3%	50%	22 1/2%
Middle & Ring	50%	33 1/3%	15%
Ring & Small	35%	25%	12 1/2%
Index, Middle, Ring, & Small	100%	75%	35%
Index, Middle, & Ring	83 1/3%	60%	30%
Thumb, Index, & Middle	95%	90%	45%
Middle, Ring, & Small	66 2/3%	50%	25%
Thumb & Small	70%	55%	27 1/2%

6. DUPUYTREN'S CONTRACTURE

There must be an ODNCR and/or ANCR for Dupuytren's Contracture before schedule evaluation thereof. Schedule loss

of use should be limited to the accident or occupational disease of the folder. There is a 5% to 7 1/2% loss of use of the hand if impairment is found in one finger only. A larger schedule may be given if two or three fingers are involved and function of the hand is compromised, such as grasp power.

7. WRIST

Amputation at the wrist equals 100% of loss of use of the hand and 80% loss of use of the arm.

Ankylosis in a position of function (mild dorsiflexion) equals 60% schedule loss of

use of the hand. In any other position, (palmar, marked dorsiflexion or lateral deviation) schedule increases to 70-90%.

Radial-lateral motion (20 degrees) and ulnar motion (30 degrees): any defects in these motions are not made cumulative, but may be separately considered if other findings in the wrist are normal. Marked defects in all wrist motions should not receive a total of more than 55% since ankylosis is rated 60% loss of use of the hand.

Figure 5.
Flexion of the Wrist
(Percent Loss of Use of the Hand)

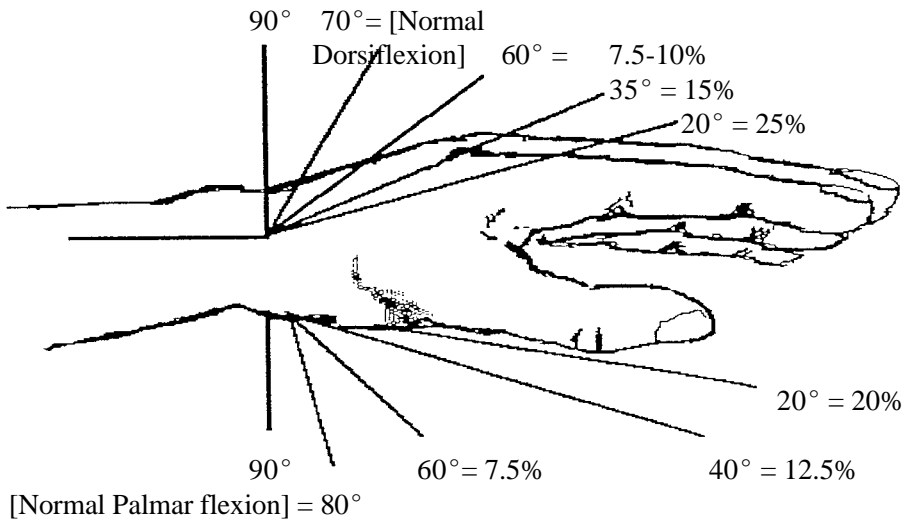

Palmar flexion (80-90 degrees average)

	%Loss of Use Of the Hand
Complete Loss	25%
Marked Defect (20°)	20%
Moderate Defect (40°)	12 1/2%
Mild Defect (60°)	7 1/2%

Dorsiflexion (70 degree range):

	%Loss of Use Of the Hand
Complete Loss	33 1/2%
Marked (20°)	25%
Moderate Defect (35°)	15%
Mild (60°)	7 1/2%

Percent Loss of Use of the Hand:
Defects of Pronation or Supination (180 degree)

	% Loss of Use of the Hand
Loss of Both	35%
Marked	25-30%
Moderate	17 1/2%
Mild	7 1/2 - 10%

Figure 6. Lateral Wrist Motion

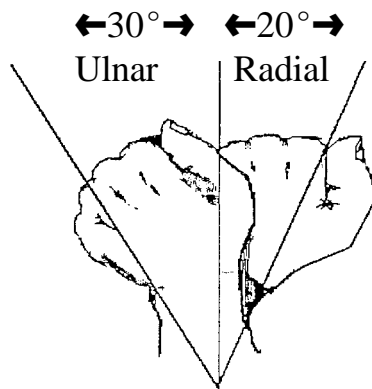

Special Considerations

1. Complete wrist drop or radial nerve palsy equals 66 2/3% loss of use of the hand; less is given for partial wrist drop.
2. Darrach procedure (resection distal ulna) equals 10% loss of use of the hand for bone loss and add for mobility defects.
3. Resection "proximal row" carpal bones equals 20% loss of use of the hand for bone loss alone.
4. Navicular fracture - Hold non-union cases for two years. Give a schedule loss of use of the hand if the X-rays provide evidence of clinical union (fibrous) and if the pain is not severe. In rare, very painful condition, consider classification.
5. Kienböck's Disease - aseptic necrosis of carpal lunate. Hold until X-rays show static condition. Consider classification if condition is symptomatic.
6. Carpal Tunnel Syndrome - schedule one year post decompression if asymptomatic. If symptoms persist and become severe and disabling, consider classification.
7. DeQuervain's Disease with or without surgical release equals 7 1/2% to 20% loss of use of the thumb depending on impairments. If there is a residual defect of the wrist and the grip power of the hand is impaired, give a schedule loss of use of the hand.
8. Ganglion of wrist equals zero to 7 1/2% of hand depending on clinical findings.

Figure 7. Supination-Pronation of the Wrist

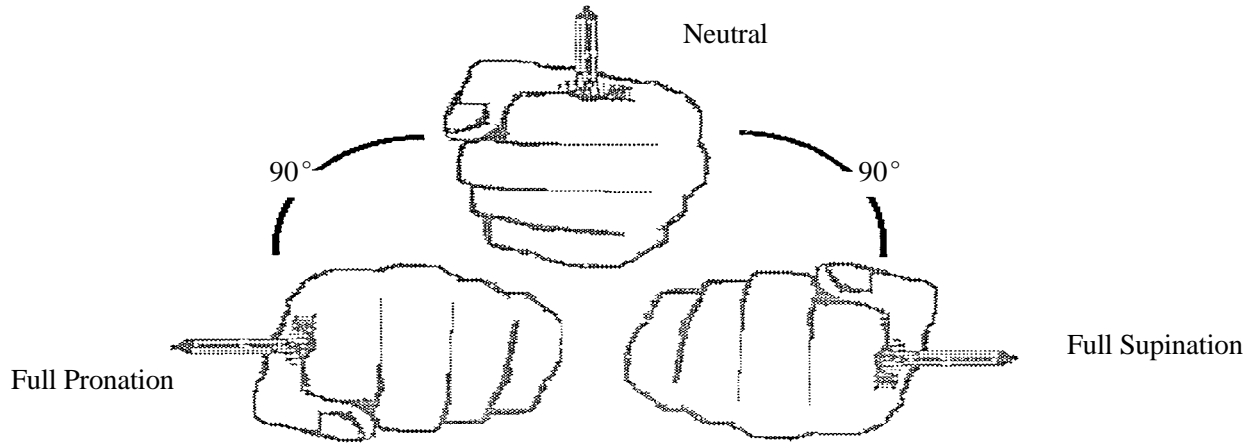

8. ELBOW

Percent Loss of Use of the Arm:
Amputation at Different Levels

Amputation	% Loss of Use of the Arm
At Elbow or Above	100%
Three Inches Below Elbow	95%
Mid-Forearm	90%
At Wrist Joint	80%

Ankylosis of the elbow in functional position equals 66 2/3% loss of use of the arm. Higher percentage is given for

extremes of flexion or rotation of the forearm.

Percent Loss of Use of the Arm:
Extension Defects of the Elbow

Range of Motion	% Loss of Use of the Arm
150 degree flexion to 45 degree extension	25%
150 degree flexion to 90 degree extension	50%
150 degree flexion to 125 degree extension	85%

Figure 8. Percent Loss of Use of the Arm: Flexion Defects of the Elbow

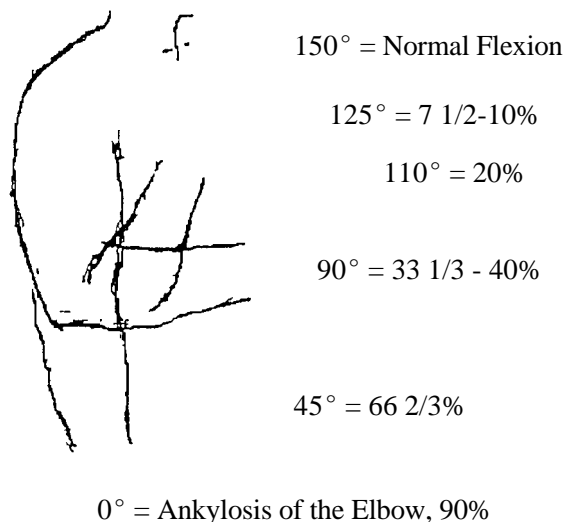

Flexion Defects of the Elbow	% Loss of Use of the Arm
To 45 degrees	66 2/3%
To 90 degrees	33 1/3%
To 110 degrees	20%
To 125 degrees	7 1/2%

Special Considerations

1. Loss of head of the radius equals 10% loss of use of the arm and add for mobility defects.
2. Laxity of the elbow with hyperextension defect equals 10 to 15% loss of use of the arm.

3. Medial and lateral epicondylitis are usually given a schedule, but if it becomes chronic, severe and disabling, consider classification.
4. Olecranon fracture and olecranon bursitis. Schedules depend on residual defects.
5. Olecranon excision equals 10% loss of the use of the arm for bone loss and add for mobility defects.

9. SHOULDER JOINT

1. Amputation from elbow to shoulder equals 100% loss of use of arm.
2. Ankylosis at scapulo-humeral joint at 0 degree equals 80% loss of use of the arm.
3. Abduction to 90 degrees equals 40% loss of use of the arm. Do not add mild defects of internal and external rotation to avoid cumulative values. May add 10-15% for marked defects of rotation and muscle atrophy.
4. Mild defect of adduction equals 7 1/2 to 10% loss of use of the arm.
5. Mild defect of posterior extension equals 7 1/2 to 10% loss of use of the arm.

Percent Loss of Use of the Arm:
 Anterior Flexion Defects of the Shoulder

Anterior Flexion to	% Loss of Use of the Arm
135 degrees	20%
90 degrees	40%
45 degrees	60%
25 degrees	70%

Figure 9.

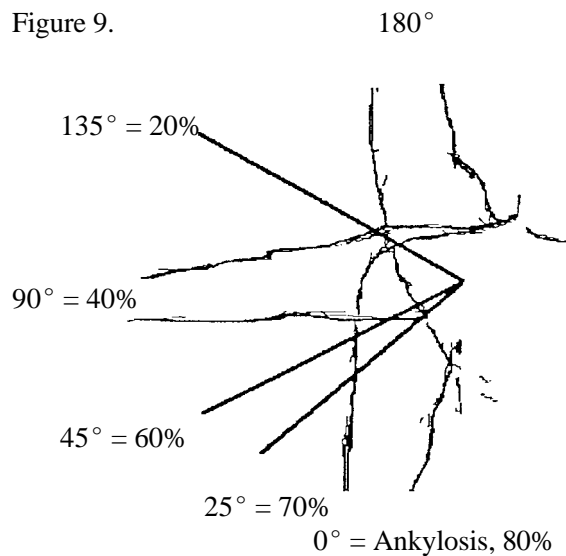

Complete loss of internal and external rotation equals 30% loss of use of the arm; 15% loss of use of the arm is given for each complete loss of motion.:

Marked defects of both internal and external rotation equals 20-25% loss of use of the arm.

Moderate defects of internal and external rotation equals 15% loss of use of the arm.

Mild defects of internal and external rotation equals 10% loss of use of the arm.

Mild defects of internal rotation equals 7 1/2% loss of use of the arm.

Mild defects of external rotation equals 7 1/2% loss of use of the arm.

Special Considerations

1. Dislocation of the shoulder: Do not give a schedule award until no recurrence has occurred for one year. Give a schedule award one year after the successful corrective surgery. Pre-existent recurrent dislocation of the shoulder calls for an overall schedule and apportionment.
2. Fracture of the clavicle equals zero to 10% depending on degree of impairment.
3. Acromio-clavicular or sterno-clavicular separation equals 7 1/2 to 10% loss of use of the arm.
4. Winged scapula due to Serratus Anterior Palsy and/or Trapezius Palsy may be given 15-20% loss of use of the arm depending on degree of functional impairment. For such cases do not give a schedule until two years post surgical repair of a major nerve.
5. Resection of the clavicle, either end, equals 10% for bone loss; entire clavicle equals 15% loss of use of the arm. Add for mobility defects if present.
6. Resection of the head of the humerus with prosthesis equals 50% loss of use of the arm for anatomical bone loss. Add for mobility defects to a final schedule of 60 to 66 2/3% loss of use of the arm.
7. Rupture of the long head of the biceps muscle is equal to 10-15% loss of use of the arm. Rupture at distal point of insertion of the biceps is equal to 20% loss of use of the arm. Taking into consideration mobility and muscle weakness, the schedule can vary up to 33 1/3% loss of use of the arm depending on degree of impairment found.

8. Rotator cuff tear with or without surgery is given for 10-15% loss of use of the arm and add for mobility defects.
9. Frozen shoulder and adhesive capsulitis (with or without surgery): if the condition is asymptomatic give a schedule loss of use of the arm. If extremely painful and all modalities of treatment exhausted, consider classification after two years.
10. The schedule given is focused on the highest valued part of the extremity. In case of a high schedule for one given part of the extremity calculate first for the major loss in part involved. For example, amputation at the wrist equals 100% loss of use of the hand or equals 80% loss of use of the arm. If there are additional defects of the elbow and/or shoulder add 10% to the 8% loss of use of the arm and the final schedule would be 90% loss of use of the arm.
11. Total joint replacement of the shoulder should be evaluated as other joint replacements taking into consideration anatomical bone loss, mobility defects and muscle atrophy. Excision of the humeral head as with excision of the head of the femur is equal to 50% for anatomical bone loss. Should add 10 to 15% for defects of mobility and muscle atrophy. Final schedule should be 60 to 66 2/3% of the arm.

B. LOWER EXTREMITIES

1. HIP

Amputation at any level from the knee joint to the hip joint equals 100% loss of use of the leg.

Ankylosis at 0 degree at the hip joint equals 80% loss of use of the leg. Higher schedule. is given for abnormal positions.

Percent Loss of Use of the Leg:
Anterior Flexion Defects of the Hip

Anterior Flexion of the Hip to	% Loss of Use of the Leg
90 degrees	10%
45 degrees	33 1/3%
25 degrees	66 2/3%

Posterior extension equals 7 1/2% to 10% loss of use of the leg.

Normal abduction is 45 degrees and normal adduction is 35 degrees and loss of both equals 33 1/3% loss of use of the leg. Marked defects of both equals 25% loss of use of the leg; moderate defects of both equals 17 1/2%; mild defects of both equals 10%. Mild defect in one motion equals 7 1/2% loss of use of the leg.

Internal and external rotation: loss of both equals 30% loss of use of the leg. Marked defect of both equals 25%; moderate defect of both equals 15%; mild defect of both equals 10%. Mild defect in one equals 7 1/2% loss of use of the leg.

Shortening or lengthening of the leg equals 5% schedule loss of use of the leg for 1/2 inch, 7 1/2% for 3/4 inch and 10% for 1 inch.

Special Considerations

1. Quadriceps Rupture: allow 15-20% for deformity and weakness. Add for mobility defects. Average schedule is 20-25% schedule loss of use of the leg. If

laxity of the knee is present, consider a higher schedule.

2. Quadriceps atrophy with weakness of extension of the knee equals 10% schedule loss of use of the leg.
3. Excision of the head and neck of the femur with or without prosthetic replacement equals 50% schedule loss of use of the leg for anatomical loss. Add for mobility defects. Total hip replacement has an average schedule of 60-66-2/3% schedule loss of use of the leg.
4. Amputee with 100% loss of use of the leg can receive an additional schedule award for a second accident or consequential injury (e.g., hip fracture).

5. Hip fracture with or without surgery requires two years before final evaluation for schedule award. Request for up to date X-ray to rule out aseptic necrosis of the femoral head, loosening and displacement/malalignment of hardware. Evaluate for schedule award six months after removal of metallic fixtures
6. Synovitis of the hip, bursitis (Iliopsoas bursa, trochanteric bursa, ischiogluteal bursa): defer final evaluation for two years and usual schedule award is 0 to 7 1/2% loss of use of the leg.
7. Fractured pelvis could be given a schedule award at end of two years if there is residual impairment to the hip, such as restriction defects of mobility of the hip joint and atrophy of muscles of the thigh. Usual schedule is 15 to 20% loss of use of leg.

Figure 10.

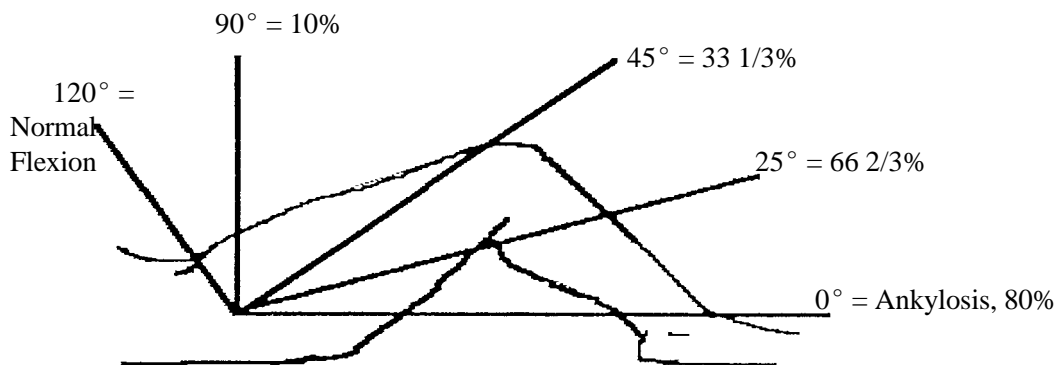

2. KNEE

Amputation at knee joint equals 100% loss of use of the leg; at six inches below the knee equals 95%; at mid-calf equals 90%. In case of subsequent injury an amputee who has received a 100% schedule loss of use of leg may receive an additional schedule award.

Ankylosis at 0 degrees equals 70% schedule loss of use of the leg. Higher schedule is given for abnormal flexion ankylosis.

Figure 11.1 Percent Loss of Use of the Leg: Flexion Defects of the Knee

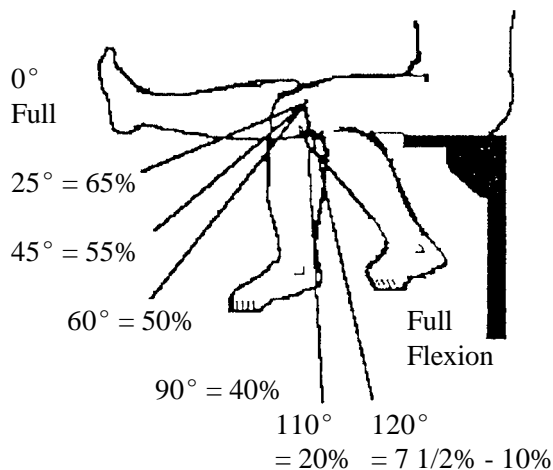

Mild defect of extension of the knee equals 7 1/2-10% schedule loss of use of the leg.

Mild defect of flexion and extension equals 10-15% schedule loss of use of the leg; moderate defects of flexion and extension equals 40-45%; marked defects of flexion and extension equals 66 2/3%.

Flexion limited to	% Loss of Use of the Leg
25 degrees	65%
30 degrees	60%
45 degrees	55%
60 degrees	50%
90 degrees	40%
110 degrees	20%
120 degrees	7 1/2% - 10%

Figure 11.2 Percent Loss of Use of the Leg: Extension Defects of the Knee

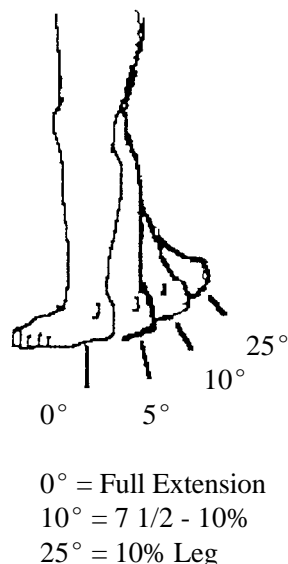

Special Considerations

1. Patella: total excision equals 15% loss of use of the leg; partial excision equals 7 1/2-10%; Add for mobility defects and atrophy of muscles.
2. Patella fracture with internal fixation equals 7 1/2-10% loss of use of the leg.
3. Recurrent dislocation of the patella with or without surgery equals 10-15% loss of use of the leg if residual impairment is present.
4. Chondromalacia patella, mild to marked degree, equals 7 1/2-10% loss of use of the leg, depending on the defects of motion and atrophy of muscles found.
5. Prepatellar or infrapatellar bursitis equals 0 - 7 1/2% loss of use of the leg.

6. Rupture of the quadriceps tendon and patella ligament equals 10%- 15% loss of use of the leg.
7. Fracture of the tibial plateau equals 10 - 15% loss of use of the leg.
8. Osteochondritis desiccans with or without surgery equals 7 1/2 - 10% loss of use of the leg.
9. Medial or lateral meniscus excision, for one or both, equals 7 1/2-10% loss of use of the leg. With joint defects and muscle atrophy average award is 15 - 20%. Partial excision of the meniscus without defects equals 7 1/2% loss of use of the leg. Excision of the meniscus should be documented by operative report or pathological report.
10. Instability of the knee cannot be scheduled unless corrected by surgical reconstruction. If surgery fails and instability persists which will require the use of a brace, consider classification. Laxity of the ligaments (anteroposterior or lateral medial) is given a schedule loss of use of the leg.
11. Total knee replacement: Unlike the total hip replacement, there is no significant bone loss with TKR and the 50% given to anatomical loss does not apply. In almost all cases of TKR, knee flexion is usually limited to 90 to 110 degrees which is equal to 35 to 40% loss of use of the leg. Add 10-15% for bone loss and the final schedule is 50-55% loss of use of the leg. Unfortunately, TKR wears out within ten to twelve years and may need a revision. Revision surgery tends to be less successful and have more complications than initial replacements. For these reasons, one may consider classifications rather than a schedule loss of the leg.

12. In non-functional prosthesis of an amputee with residual symptoms and complications, such as neuroma, phantom pain and chronic ulcers, consider classification.
13. Recurrent locking of the knee may not be amenable for schedule and should be disposed as a classification.
14. Tibial shaft fracture healed and no malalignment equal 0 - 10% loss of use of the leg.

3. ANKLE AND FOOT

Amputation at the ankle joint equals 75% schedule loss of use of the leg.

Ankylosis at 0 degrees equals 60% schedule loss of the foot. Give higher schedule for abnormal position of ankylosis.

Percent Loss of Use of the Foot:

Plantar flexion (normal = 40°)	% Loss of the Use of the Foot
Complete Loss	35%
Marked Defect	25%
Moderate Defect	15%
Mild Defect	7 1/2%

Percent Loss of Use of the Foot

Dorsiflexion Defects:

Dorsiflexion (normal = 20°)	% Loss of the Use of the Foot
Complete Loss	35%
Marked Defect	25%
Moderate Defect	15%
Mild Defect	7 1/2%

Figure 12.1 Percent Loss of Use of the Foot: Flexion Defects of the Ankle

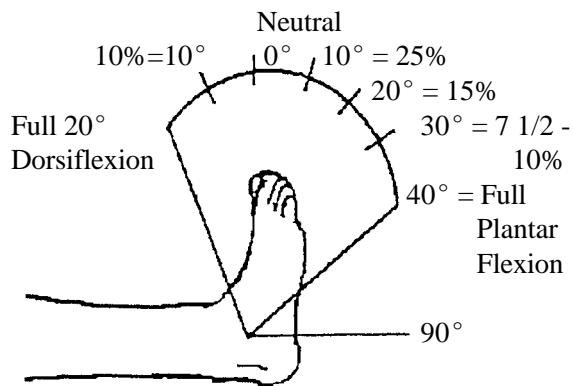

Marked plantar flexion and dorsiflexion defect equals 40% schedule loss of use of the foot.

Inversion - normal is 30 degrees and eversion - normal is 20 degrees:

Complete Loss of	% Loss of Use of the Foot
Inversion and Eversion	35%
Inversion alone	20%
Eversion alone	10%
Marked Defect of both	25%
Moderate Defect of Both	17 1/2%
Mild Defect of both	10%
Mild Defect of Inversion alone	7 1/2%
Mild Defect of Eversion alone	7 1/2%

Note that marked defects of all motions of the ankle and subtalar joint should not exceed 50-55% schedule loss of use of the foot since ankylosis is 60%.

Figure 12.2 The Subtalar Joint Motion

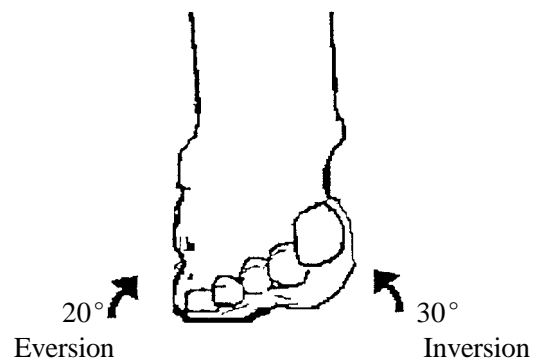
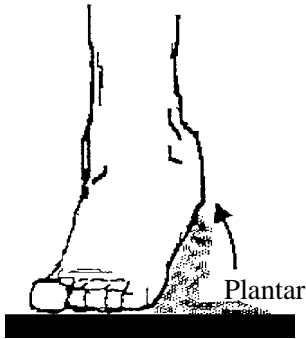

Figure 12.3 Plantar Motion



Special Considerations

1. Schedule losses must be substantiated by determination of residual permanent defects; consider tissue loss, mobility defects, sensory and motor loss, and impaired function.
2. Os calcis fracture equals an average schedule of 33 1/3% to 40% loss of use of the foot depending on residual mobility defects. If loss of height of the heel results in shortening of the leg, a leg schedule should be given.
3. Ankle fusion equals 75% loss of use of the foot which exceeds 60% for ankylosis if additional toe defects are present.
4. Complete foot drop equals 66 2/3% schedule loss of use of the foot and partial foot drop equals 20 - 33 1/3%.
5. Consider a higher schedule award for severe residual neurological deficit.

6. Rupture of the Achilles tendon equals an average schedule of 20-25% schedule loss of use of the foot.
7. Malleolar fractures (bimalleolar or trimalleolar) equals an average 20-30% schedule loss of use of the foot.

4. GREAT TOE

Amputations

- a. Amputations of the distal phalanx/distal interphalangeal joint equals 50% loss of use of the great toe.
- b. Amputation of a major portion of the great toe distal phalanx equals 50% loss of use of the great toe.
- c. Amputation at the metatarsophalangeal joint and/or proximal phalanx equals 100% loss of use of the great toe.

Defects of Mobility

Loss of active flexion or ankylosis at IP joint equals 50% loss of use of the great toe.

Loss of active flexion and/or ankylosis at MTP joint equals 75% loss of use of the great toe.

	Mild Defect	Moderate	Marked
IP Joint	10-15%	20-25%	40-45%
MTP Joint	15-20%	25-30%	45-50%
Both Joints	20-30%	40-50%	80-90%

5. SMALLER TOES (SECOND, THIRD, FOURTH & FIFTH)

Percent Loss of Use of the Toe:

Amputations, ankylosis or loss of active motion

At DIP joint	50% loss of use of the involved toes
At PIP joint	75% loss of use of the involved toes
At MTP Joint	90-100% loss of use of the involved toes

Marked, moderate, mild (DIP, PIP, MTP) are given the same schedule values as the DIP, PIP and MCP joints of the fingers of the hand.

Special Considerations (Loading)

Amputations of two or more toes are loaded 50% and converted to a foot schedule. When there is bone loss through the metatarsals, the load is 100%. When three or more toes have defects and without bone loss, the load is 25%. Amputation through the five metatarsals is loaded to 100% and converted to a foot schedule.

II. LOW BACK

A. EXAMINATION PROCESS

1. HISTORY

1. Carefully review claimant's medical file and assess the description of any pain, giving the location, character, duration and radiation in the parts involved.
2. List the factors that initiate or aggravate the low back pain.
3. Consider the history of sphincter, bowel, bladder and sexual dysfunction.
4. Note consistency of complaints, symptoms and physical findings from the date of the accident.
5. Describe mechanism of injury.
6. Consider past personal history:
 - a. Unrelated documented medical diagnoses such as diabetes mellitus, hypertension, cardiovascular disease, chronic alcoholism, chronic infection, carcinoma.

- b. Unrelated documented orthopedic and radiological diagnoses such as rheumatoid arthritis, ankylosing spondylitis, spinal stenosis, spondylolisthesis and spondylolysis.
- c. Unrelated neurological or neuromuscular disease and metabolic neuropathies.
- d. Unrelated vascular abnormalities such as peripheral vascular disease, varicosities.

7. Occupational History:

Occupation, sex and age are to be considered only by the Workers' Compensation Law Judge in his/her final determination of industrial disability, and they are not criteria to be used in evaluation of medical impairment; that is, the Workers' Compensation Law Judge considers the type and level of work, ability or inability to return to usual occupation, vocational rehabilitation and its outcome.

2. PRESENT COMPLAINT

1. Pain - mild, moderate, severe.
2. Radicular pains to legs.
3. Numbness and weakness of the lower extremities.

3. PHYSICAL EXAMINATION

1. Habitus and general posture:

obesity, hyperlordosis.

Kyphosis, scoliosis.

2. Gait Pattern:

Limping/antalgic gait.

Ataxic.

Hemiplegic.

Waddling or clumsy gait.

Steppage gait.

Hysterical gait.

Drunken or staggering gait.

3. Use of assistive device such as a cane, walker, crutches, wheelchair, leg brace, orthopedic special shoes, i.e., "shoe lifts."

4. Manner, speed of disrobing.

5. Ability to get up and approach examination table.

6. Tenderness/pain recreated by heavy percussion of the lumbo-sacral spine, sciatic notches, along sciatic nerve, spinous ligament and renal area.

7. Paravertebral muscle spasm - unilateral, bilateral, chronic and involuntary.

8. Pelvic obliquity, gluteal folds, discrepancy of leg length, deformities of the spine, and flabby abdominal muscles.

9. Spinal/truncal motion, active and passive flexion, extension, side bending and rotation:

a. observe if motion is prevented by pain or causing pain or voluntarily guarded or prevented.

b. Observe restriction of range of motion - mild, moderate, marked.

10. Straight leg raising test:

a. Check all hip movement.

b. Lassègue's, Patrick's and other sciatic nerve stretch test.

c. Extension of the femur by femoral nerve stretch tests.

11. Neurological Examination:

a. Deep tendon reflexes and pathological reflexes.

b. Sensory deficit anatomical and dermatome pattern.

c. Muscle power, weakness and atrophy.

d. Circumferential measurement of the thigh and calf for atrophy.

e. Group muscle testing of muscles of the leg, ankle and great toe.

12. Vascular examination of the lower extremities:

a. Trophic skin changes, temperature changes and signs of stasis.

b. Peripheral pulses.

c. Homan's sign.

d. Pedal edema.

B. DIAGNOSTIC PROCEDURES AND SPECIALIZED TESTS

Plain films: AP, lateral and oblique.

CAT Scan.

MRI.

Bone Scan.

Myelogram.

EMG and NCS.

Discography.

Cystometrogram and cystometrics.

Epidural venography.

Arteriography.

MRI Myelogram

C. DIAGNOSTIC FINDINGS

Degenerative changes/osteoarthritis.

Disc narrowing increased over that usual for claimant's age.

Vertebral margin osteophytes.

Spondylolysis.

Spondylolisthesis Grade 1 or more.

Spinal stenosis.

Spinal bifida occulta.

Osteoporosis and vertebral compression fracture.

Scoliosis

Metastatic tumors or carcinoma or other osteolytic and osteoblastic lesions.

Lumbarization/sacralization of lumbar vertebrae.

Fracture dislocation through the intervertebral disc.

D. OTHER IMPORTANT POSITIVE LABORATORY FINDINGS

Elevated sedimentation rate.

Elevated white blood cell count.

Hypo and hypercalcemia.

Elevated protein level in the cerebrospinal fluid.

Elevated blood sugar.

E. MODALITIES OF TREATMENT

1. Conservative Management

- a. Response to medication such as anti-inflammatory, analgesics, muscle relaxant and psychotropics.
- b. Modalities of physical medicine such as physical therapy (low back exercises), use of TENS Unit, heat (hot packs, ultra sound, diathermy).
- c. Use of bed boards, spinal braces, corset, shoe lifts.
- d. Local anesthetic injections, infiltration to facet joints, bursa,

trigger zone, nerve blocks and epidural steroid injections.

- e. Chiropractic manipulations.
- f. Acupuncture, etc.
- g. Referral to Back School with multi disciplinary approach.
- h. Work hardening program.

2. Surgical Management

- a. Laminectomy (decompression); laminotomy; result: good, failed and repeat.
- b. Microdiscectomy.
- c. Spinal fusion with autogenous graft, allograft, or both, good result, failed or revision.
- d. Combination of multiple surgical procedures.

3. Other Modalities of Treatment:

- a. Chemonucleolysis.
- b. Chronic pain program clinic and management.
- c. Psychotherapy and psychiatric treatment.

F. CRITERIA THAT MAY BE USED FOR EVALUATION OF DEGREE OF PARTIAL DISABILITY

The following criteria of degree of impairment should be reflected in every medical report and should assist the Law Judge in his/her final decision on the degree

of industrial disability.

Mild

- 1. Only subjective complaints of long duration with minimal physical findings.
- 2. Positive chronic involuntary muscle spasms and specific tenderness and no neurological deficit.
- 3. Mild defects of involuntary trunk mobility.
- 4. Good response to conservative treatment.
- 5. X-ray evidence of degenerative disc and/or joint changes, equivocal CAT scan and/or MRI.

Moderate

- 1. Long history of chronic pain with correlative positive physical findings.
- 2. History of radicular pain to the legs with positive physical findings such as straight leg raising test.
- 3. One or two positive diagnostic tests such as X-rays, CAT Scan, MRI, EMG, NCS, and Myelogram.
- 4. Surgery with good results, laminectomy, spinal fusion and chemonucleolysis.
- 5. Poor response to conservative treatment and poor response to chiropractic treatments.
- 6. Referred to office of Vocational and Educational Services for Individuals with Disabilities (VESID).

Marked

1. Chronic pain and with a history of continuous use of multiple drugs such as analgesics, anti-inflammatory and psychotropics.
2. Long history of failed and repeated conservative treatments.
3. Persistent radicular pains to the lower extremities and positive correlative physical findings of radiculopathy.
4. Significant gait deviation and continued use of assistive device such as a cane, spinal brace, etc.
5. Difficulties negotiating stairs and irregular terrain.
6. Back or leg pain, causing interference with standing, prolonged sitting such as driving continuously for two hours at a time.
7. Markedly limited truncal mobility.
8. Positive neurological findings such as SLR tests; reflex, sensory and motor abnormalities.
9. Neurogenic claudication.
10. Positive diagnostic tests such as X-rays, CAT Scan, MRI, EMG, NCS, and Myelogram.
11. Failed or poor response to surgical procedures such as laminectomy, spinal fusion and chemonucleolysis.
12. Poor response to chronic pain management treatment.
13. Bladder, bowel and/or sexual dysfunction.

G. DETERMINATION OF TOTAL DISABILITY

Include criteria and factors used for marked partial disability as listed above and add the following criteria below:

1. Use of assistive device to ambulate such as walker, crutches and/or wheelchair of more than two years duration.
2. Needs assistance to undress or disrobe and unable to get up to the examination table without assistance.
3. Needs assistance to perform the activities of daily living such as self care, personal hygiene and transportation.
4. Severe neurological deficit such as marked muscle weakness, paraplegia and paraparesis.
5. Disturbance of bladder, bowel and/or sexual function.

H. FINAL ASSESSMENT OF LOW BACK EXAMINATION

The Law demands to know the results of disability evaluation in more or less inflexible or absolute terms. The examining physician is confronted with factors in disability, and to satisfy the letter of the Law, an examining physician has to try to convert variables into constants. Disability evaluation is not an exact science. Despite the drawbacks, it is still possible, within the realm of medical probability, good clinical judgment and impartiality, to arrive at a just and equitable evaluation.

I. CONCLUSION OF CAUSALLY RELATED SPINAL INJURIES (NECK AND LOW BACK)

The examining physician assesses all the data and formulates an opinion and conclusion, which may be one of the following:

- a. Partial Disability
- b. Temporary Total Disability
- c. No Disability

Claimants with continuing temporary partial or total disability with cases approaching or having exceeded two years in duration may have a finding of permanency. This is when a classification is called for. Classification is a legal decision and is a means of disposition of cases with a continuing or progressive impairment resulting in a disability in the performance of previous customary work.

It is important that the examining physician feels that full recovery is unlikely and all avenues of reasonable medical and surgical treatment have been explored. This conclusion may be one of the following:

- a. Permanent Partial Disability.
- b. Permanent Total Disability.

III. CERVICAL SPINE INJURIES DUE TO TRAUMA

A. PATHOPHYSIOLOGY

Review of the pathophysiology of the injuries of the cervical spine:

Although trauma may involve the spinal cord alone, it is seldom that the vertebral column is not injured at the same time. Often there is an associated head injury as well. A useful classification of cervical spine injuries divides them into fracture dislocations, pure fractures and pure dislocations. Usually the same mechanism is causative. There is vertical compression with forced flexion or extension. Industrial accidents most often involve the dorsolumbar vertebrae. Falls, head down, involve the cervical spine (e.g., diving accident). Crushing industrial accidents, automobile accidents and falls down stairs are the most common causes of cervical spine injury.

Pre-existing cervical spondylosis is important to note in claimants over the age of forty-five. In the presence of spondylosis, damage to the cervical spinal cord is due to sudden narrowing of the spinal canal. The cord is caught between the laminae of the lower vertebrae and the body of the higher one. The ligamentum flavum may buckle and compress the cord. Ischemic cord changes may occur.

The cervical spinal cord can be injured without evidence of fracture or dislocation. Extremes of flexion and extension (whiplash) can also injure the cord or cervical roots. Pathophysiology is either a transient posterior dislocation or a momentary retropulsion of the intervertebral disc into the spinal cord. The presence of cervical spondylosis adds to the hazards of damage to the cord or roots. Violent falls on the back may cause a cervical spine concussion, usually with transient weakness.

With cervical cord transection due to trauma, a permanent total disability may ensue with paraparesis or paraplegia and bowel incontinence. With a cord concussion, the disability may be partial, with symptoms regressing in weeks.

Pain in the neck and shoulders not related to a cervical fracture dislocation or variants should be divided into three categories of painful disease. Consider less severe injuries to the cervical spine, brachial plexus injuries (thoracic outlet syndrome) or diseases of the shoulder itself (capsular tears).

Neck pathology is associated with limited neck movements. Joint pathology of the shoulder is manifested by focal tenderness weakness and decreased range of motion. Cervical disc herniation may be associated by weakness of muscle groups, loss of sensation in a dermatome distribution and reflex changes.

Clinically significant deep tendon reflexes of the upper extremities include:

1. Biceps reflex - affects arm flexion, root involved is C5 and C6 via musculocutaneous nerve.
2. Brachialis reflex - affects arm flexion, root involved is C5 and C6 via radial nerve.
3. Triceps reflex - affects arm extension, root involved is C6 and C7 via the radial nerve.

The most common level for cervical disc herniation is C5 and C6. With a herniation at this level, the biceps and brachioradialis reflex may be hypoactive or absent, and the triceps reflex may be brisk. Additionally, the brachioradialis may be paradoxical with no arm flexion, and/or finger flexion occurring.

Cervical disc herniation with or without neurological deficit and with or without surgery are not amenable to a final adjustment. They are like lumbar disc herniations classified as permanent partial disability or permanent total disability.

B. EXAMINATION PROCESS

1. HISTORY

2. PRESENT COMPLAINT

1. Pain-acute/chronic/character/localized or radicular to arms, hands and fingers.
2. Weakness and numbness of arms, hands and fingers.
3. Muscle spasm, paracervical muscles, trapezius.
4. Stiffness, especially weather changes and in getting up in AM.

3. PHYSICAL EXAMINATION

1. Observe ability to undress, unbutton shirts, wears cervical collar.
2. Observe shoulder level.
3. Palpation for spasm of paracervical muscles, trapezius, trigger points.
4. Active and passive range of motion of cervical spine and shoulders.
5. Neurological deficit of the upper extremities such as weakness, atrophy of muscles, pronator drift and grip power.
6. Deep tendon reflexes, biceps, triceps and brachioradialis.
7. Sensory loss.

C. DIAGNOSTIC TESTING AND INTERPRETATION OF FINDINGS

X-rays of cervical spine, AP, lateral and oblique

EMG and NCS

CAT Scan

MRI

Bone Scan

Discogram

Myelogram

D. TREATMENT

Modalities of treatment of cervical spine injuries are similar to modalities of treatment for the low back (both conservative and surgical approach).

E. FINAL ASSESSMENT OF DISABILITY OF THE CERVICAL SPINE

Criteria that may be used for evaluation of the degree of disability of the low back injuries may be applied in the assessment of cervical spine injuries.

Note: Refer to the nervous system section for cervical cord injuries.

IV. NERVOUS SYSTEM

CENTRAL NERVOUS SYSTEM

A. CRANIOCEREBRAL TRAUMA

Concussion implies violent shaking and agitation of the brain or the transient functional impairment (viz unconsciousness) which results therefrom. Brain may also suffer gross damage without skull fracture, such as contusion, laceration, hemorrhage, swelling and brain herniation through the tentorium cerebelli.

B. SEQUELAE

It is estimated that 10% of cases of significant head trauma (i.e., loss of consciousness) are associated with convulsions soon following trauma or many years later. If seizures are documented and persist, the examiner must consider a permanent partial disability. By two years time from the date of trauma, 80% of those who have had seizures, will already have experienced them. Neurological evaluation is imperative.

One may have a transient paralysis with a concussion with no permanent sequelae. Two years of observation are needed. Antegrade and retrograde amnesia are usually transient as well as associated headache, giddiness, fatiguability, insomnia and nervousness.

Claimants may remain in a coma due to brainstem injury for prolonged periods without subsequent sequelae. Defer final evaluation for two years for such cases may lead to a classification and/or a facial disfigurement (with esotropia and the like). Cranial nerve palsies are frequently seen with brainstem lesions.

With cortical injury, the claimant may have a persistent hemiparesis or hemiplegia (permanent total disability) or a hemianopsia (temporary total disability), expressive and receptive speech disorders (partial or total depending on degree), apraxia, agnosia and central types of hypesthesia and pain syndromes on a central basis, i.e., the thalamic syndrome of Dejerine and Roussy. Brainstem and cortical lesions may be associated with pain syndromes.

Hypothalamic injury may result in diabetes insipidus, narcolepsy or the Klein Levin Syndrome of morbid hunger and excessive sleep and may explain posttraumatic amenorrhea and loss of sexual desire and potency.

Personality and behavioral disorders may occur. Symptoms may be similar to those following a prefrontal lobotomy if there was selective frontal lobe damage with apathy, inappropriate frivolity (Witzelsucht), indifference, lack of spontaneity

with a blunting of emotional control (bursts), delicacy of feeling, consideration of others and forethought.

An extradural hematoma if not quickly evacuated leads to a most severe neurological sequelae or death due to arterial bleeding.

Subdural hematomata are usually slow growing due to venous oozing and as a rule do not result in permanent neurological deficits. Hemiparesis is unusual as a sequelae unless there is a significant associated contusion (visible on CT and MRI).

C. CRANIAL NERVES

1. First Nerve

Anosmia may be a sequelae of frontal trauma (coup or contra coup) due to fracture of the cribriform plate or injury to the perforating filaments of cranial nerves. Most common cause of anosmia is an upper respiratory infection. Anosmia may be clinically related to a fracture of the ethmoid. To differentiate from hysteria use spirits of NH₄ (appreciation of which is a function of cranial nerve V (pain)). Loss of both suggests hysteria.

2. Third, Fourth, & Sixth Nerve

Anisocoria due to trauma with Third Nerve involvement and lid droop (ptosis) may occur as well as involvement of the ciliary ganglion branches (sphincter of iris) with dilatation and reflex iridoplegia. If **complete, the eye** is turned outward/downward and the pupil is dilated. Fourth Nerve palsy results in diplopia looking downward (palsy of the superior oblique). With Sixth Nerve palsy there is a weakness or paralysis of abduction with a convergent squint. The clouding of the cornea, aphakia or other sequelae of eye injury may result in a permanent facial disfigurement.

3. Fifth Nerve

Any of the three branches: -- ophthalmic, maxillary or mandibular -- may be associated with a basal skull fracture due to trauma. Etiology of trigeminal neuralgia (douloureux) is not clear. Although disabling, it is not usually compensable. Bite function (masseters muscle) is the motor component of the Fifth Nerve.

4. Seventh Nerve

Traumatic injuries in the upper neck or face may involve the facial nerve. There is a loss of volitional and emotional movement of the affected side. There is an inability to elevate the eyebrow, frown, close the eye, show teeth, whistle, or purse the lips. In attempting to close the eyes the globe rolls upwards (Bell's phenomenon), on drinking, fluid spills from the affected side. If the stapedius muscle is affected there may be hyperacusis. Etiology of Bell's Palsy is unknown. Possible cause could be swelling of the stylomastoid foramen. At times it is viral with eruptions (Herpes Zoster) in the external auditory canal (Ramsey Hunt Syndrome). The etiology is obvious and not compensable. As a rule it is not a compensable injury unless there is facial or appropriate neck injury. Loss of taste on up to 2/3 of the ipsilateral tongue may occur.

5. Eighth Nerve

Eighth Nerve Components - cochlear (auditory) and vestibular (equilibrium). Unilateral loss is not that disabling but partially so. Bilateral loss is very disabling because of an impairment of communication. This can be a rather severe industrially related disability.

6. Ninth, Tenth and Eleventh Nerve

Not usually related to compensable injuries.

7. Twelfth Nerve

Unilateral loss is not really disabling and is

usually related to a brainstem infarction and not trauma.

D. MOTOR SYSTEM DEFECTS

1. Cortex

Motor defects may be central as with traumatic injury to the motor neurons (frontal cortex) with a resultant hemiparesis or hemiplegia which could be permanent and could result in a permanent total disability. With this type of weakness there is spasticity, clonus and long tract signs due to injury of the inhibitory neurons and fibers potentiating the reflex arc. This may follow penetrating wounds of the skull, e.g., bullet wounds, or may be due to severe contusions with focal cortical atrophy. A chronic subdural hematoma (cystic hygroma) is usually reversible but may result in a mild hemiparesis (permanent partial disability) and is usually associated with dysphasia and dysgraphia. Extensor muscles are more affected than flexor in the arms whereas in the legs flexor are more affected than extensors. Recovery is usually better in the lower limbs than in the arms. Babinski's sign is characteristic of upper motor neurons involvement: cortex or spinal cord.

2. Spinal Cord

Cervical lesions, e.g., vertebral fractures with cord compressions or subluxation with prolonged cord compression, will involve upper and lower extremities if high (i.e., above C4 and C5). One may see a flaccid paralysis in the upper extremities and a spastic paralysis of the lower extremities.

Reflex levels are important clinically. A claimant who has brisk biceps, triceps, supinator, finger, knee and ankle jerks, and a positive Babinski's sign with absent abdominal reflexes must have a lesion above C5 in the cervical cord. If the jaw jerk is absent, it is pons; in addition, if cranial nerves are spared, it is below the foramen

magnum.

Segmental Level of Reflexes Corneal

Corneal	Pons
Jaw	Pons
Pharyngeal	Medulla
Biceps	C-5 - C6
Supinator	C-5 - C6
Triceps	C-6 - C7
Finger (Hoffman's)	C-8
Upper Abdominal	T8 - T9
Lower Abdominal	T11 - T12
Knee	L2 - L3 - L4
Ankle	L5 - S1
Plantar	L5 - S1

If deep tendon reflexes of the upper extremity are normal and the upper abdominal and cremasteric reflexes are absent, likewise the knee and ankle jerks are pathologically brisk and the plantar response is extensor, a lesion at T10 is most likely.

Fracture dislocations occur most frequently at the lower cervical area (C5, C6), usually following falls on the head, auto accidents and diving injuries. Fracture dislocation at the thoracolumbar junction usually results from falls from a height onto the feet or buttocks or from flexion injuries of the spine (such as heavy weights falling on the shoulders). Cervical spondylosis renders the cervical cord very vulnerable to extension injuries.

Spinal Concussion is a term applied to transitory disturbances of cord function resulting from a violent blow to the vertebral column, such as a blast injury or the passage of a high velocity missile through tissue adjacent to the cord.

Syringomyelia is congenital in origin; however cavities of the cord with similar symptoms may be secondary to trauma to the cord.

E. SENSORY DEFECTS

Cortical injury is involved in discriminative and interpretive aspects of sensation, in the recognition and localization of light touch, in distinguishing degrees of temperature, and in the discrimination of texture, consistency, weight, size, shape and form. Parietal lobe sensation defects include extinction on simultaneous stimulation, graphanesthesia and autotopagnosia.

Spinal cord lesions involve the appreciation of pain and temperature at two levels below the actual lesion. A traumatic compression or hemisection of the cord at T8 and T9 will cause a sensory loss at the umbilicus, T10.

Radiculopathy or sensory root disturbances are of dermatomic distribution. Because of sensory

overlapping, involvement of one root is unlikely to produce much sensory loss except in the periphery of the limbs, where overlapping is less and where sensory impairment is likely to involve pain appreciation, such as a C5 root involvement may cause hypesthesia over the thumb and a C7 lesion resulting in a sensory loss over the middle finger. Accordingly a L5 lesion can cause a sensor~ loss over the great toe and an S1 lesion over the lateral foot.

F. CONCLUSIONS

Evaluation of a claimant with central nervous system dysfunction can be quite a challenge. A complete history is most important. Neurological and neurosurgical reports are important as are the hospital records especially with claimants who have had head trauma. Duration of loss of consciousness or confusional states are important. Reports of skull X-rays, EEG abnormalities with focal slowing or post traumatic spike activities should be noted.

A CT scan of the brain and MRI are important to evaluate structural brain changes that correlate with the clinical picture. If there are changes in speech, an evaluation by a speech pathologist must be obtained. Psychological testing is needed to ascertain the type and degree of dementia, as well as behavioral changes present.

On physical exam, note whether speech is spastic or scanning and slurred. There may be an element of expressive (motor) or receptive (sensory) dysphasia. Note hemiparesis or hemiplegia. Note if there is a gait disturbance. Disability may be partial, may be temporary total, or if neurologic defects are severe and permanent, may be permanent total. If post-traumatic seizures occur, a permanent partial disability (classification) might be appropriate. Note drugs needed to control the condition.

Conclusion at the time of evaluation depends on subjective and objective findings. Residual

neurological deficit are most important in loss of function. Permanent disability can only be determined two or more years following the reported date of injury.

In summary the following criteria are most important in the evaluation of partial and total disability of the central nervous system:

1. Level of consciousness from subtle confusion to stupor and coma.
2. Impairment or loss of higher and complex cerebral function such as orientation, memory, judgment, decisions and planning (could be subtle and may need psychological evaluation and testing).
3. Impairment of speech and language, comprehension, expression or both.
4. Sensory and motor impairments, including
 - a. Ability to perform various functions of daily living.
 - b. Station and gait and need to use assistive device such as a cane, walker and/or wheelchair.
5. Loss of control of bladder and bowel and loss of sexual function.

The examining physician is left to make a final decision on partial and total disability depending on the severity of the above impairments and the degree of loss of function. Head injuries with residual hemiplegia and aphasia are classified permanent total disability. Spinal cord injuries with residual quadriplegia and paraplegia are also classified permanent total disability.

Post concussion syndrome and subdural hematoma, with or without residual symptoms and with or without neurological deficit, are classified permanent partial disability. Isolated cranial nerve injuries are rare and are usually classified permanent partial disability.

G. PLEXOPATHIES

Brachial plexus injury is most frequently due to excessive stretching and compression, such as in carrying heavy weights or being in a prolonged position during anesthesia, or to gunshot wounds. Avulsion of the cervical nerve root can produce a similar picture. Vehicular trauma may at times result in a complete brachial plexopathy with a paralyzed arm and total absence of reflexes.

A severe brachial plexopathy may cause a temporary total disability due to severe loss of function and pain. A milder involvement may result in a partial disability but wait for at least two years to see if defects ensue which might lead to a permanent disability or a schedule loss.

Upper brachial plexopathy affects the biceps, deltoid, supinator longus, brachialis, supraspinatus, infraspinatus and rhomboid muscles, and results in a sequelae with the arm hanging to the side and internally rotated. Hand motion is unaffected. Prognosis for recovery is good, although at times return of function is not complete. Reevaluate after two years for return of function, at which time it may be amenable for a schedule loss of use of the arm.

Lower brachial plexopathy can be associated with surgery or falls on the abducted arm. There is weakness and wasting of the small muscles of the hand and may result in a characteristic claw hand deformity. Such cases are usually given a high schedule loss of use of the hand.

Brachial plexopathies, even after a rib resection, usually lend themselves to a final adjustment after a two year period. Persistent severe weakness and intractable pain might necessitate considering a partial disability which might lead to a classification.

H. THORACIC OUTLET SYNDROME

Thoracic outlet syndrome may be related to an anomalous cervical rib, anterior scalene hyperplasia and to hyperabduction. An anomalous cervical rib arising from the 7th cervical vertebra can extend laterally between the anterior and medial scalene muscles disturbing the outlet and compressing the brachial plexus. The subclavian artery can also be compressed. Five tenths percent of the population have cervical ribs, ten percent of which are symptomatic. Sagging shoulders may have significance in women; occupational activities may play a part both in males and females. Pain and paresthesia are most commonly found. Adson's sign is helpful in making the diagnosis. The technique of performance of the test for obstruction of the subclavian artery by the scalenus anticus muscle is as follows: claimant is seated with elbows at sides and neck extended. During deep inspiration the chin is turned downwards towards the affected side while the radial pulse is palpated and there may be total obliteration. Nerve conduction studies and angiography may not be too helpful in making the diagnosis. It can be confused with cervical discs, carpal tunnel syndrome or ulnar nerve compression at the elbow. If corrected (e.g., through surgery or other modalities of treatment) and if there remain mild symptoms and mild neurological deficit, it is amenable to schedule loss of use of the arm; if symptoms and deficits are severe and disabling, then consider classification.

I. ENTRAPMENT NEUROPATHIES

Pathophysiology: a nerve passing through a tight canal trapped and subjected to constant movement or pressure. The epianid perineurium become greatly thickened strangling the nerve with ischemic damage. Sensory, more than motor

function, is impaired and symptoms fluctuate with activity and rest.

The following entrapment neuropathies have been delineated:

Nerve	Site/Entrapment
Median	Transverse Carpal Ligament (Carpal Tunnel)
Ulnar in Elbow	Bicipital Groove
Ulnar in Wrist	Plantar Fascia- Pisiform bone
Anterior Interosseous (Pronator Syndrome)	Between heads of pronator muscle
Lateral Femoral Cutaneous (Meralgia Paresthetica)	Inguinal Ligament
Posterior Tibial	Tarsal Tunnel - Medial
	Malleolus - Flexor Retinaculum
Plantar	Plantar Fascia
(Morton's Metatarsalgia)	Heads of 3rd & 4th Metatarsal

J. MEDIAN NERVE - (CARPAL TUNNEL SYNDROME)

This is the most common of peripheral nerve entrapment syndromes in the upper limb. The etiology is generally a compression of the median nerve due to thickening of the synovium around the flexor tendons at the wrist, i.e., hematoma, callus formation, malunited fractures, etc. Symptoms may include atrophy of the thenar eminence, tingling and numbness of the first three

and one half fingers, weakness in opposition of the thumb, positive Tinel's test and positive Phalen's test.

Occasionally there is a retrograde distribution of discomfort extending to the neck and shoulders, which may present a problem in differential diagnosis from cervical radiculitis.

Electromyography and nerve conduction studies have been employed in the diagnosis of difficult cases. Prolongation of median motor latencies is found when the median nerve is stimulated at the wrist. 85% to 95% of cases will have median sensory fiber abnormalities. Prolongation of distal sensory latency beyond 3.5mm per second is considered abnormal.

Treatment may be conservative or surgical. Conservative measures may be use of wrist support and splints, antiinflammatory medication, use of whirlpool and/or paraffin bath, and stretching exercises of the transverse carpal ligament.

The usual surgical treatment in cases with progression of symptoms such as numbness, weakness and muscle atrophy is a transection of the transverse carpal ligament which decompresses the median nerve. More recently endoscopic surgery has been very successful. Carpal Tunnel Syndrome with or without decompression are usually given a schedule loss of the hand which usually averages 10-20% loss of use. If symptoms persist and condition becomes disabling, consider classification.

K. ULNAR - (CUBITAL TUNNEL SYNDROME)

1. Elbow

The ulnar nerve is subject to direct trauma in the elbow because of its superficial position being covered by fascia and skin only. It can be one big trauma or multiple small traumata (i.e., constant pressure on the elbow). Pressure may occur during anesthesia but more commonly the nerve is

injured by being drawn tightly against the ulnar groove. The nerve is tethered as it passes through the two heads of the carpi ulnaris. Signs and symptoms are (a) burning pains and hypesthesia in the ring and small fingers, (b) inability to separate fingers due to interosseous weakness - a major portion of intrinsic muscles of the hand affected, (c) ring and small fingers are cocked up due to weakness of the flexor digitorum profundus at the MCP joint (hyperextension), (d) the hypothenar eminence flattens out due to loss of bulk. Ulnar nerve transposition is the treatment of choice. Entrapment of the ulnar nerve at the elbow is usually given a schedule loss of use of the arm if accompanied with defects at the elbow. If neurological deficit and defects of motion is confined to the hands and fingers, schedule loss of use of the hand is given.

2. Wrist

Wrist injury of the ulnar nerve: the palmar trunk and superficial branches are subject to direct trauma by force directed against the base of the hypothenar eminence as the bone rests on the thinly padded bone. The force may be a repetitive one as from use of a particular tool or instrument in industry such as pliers or a screwdriver. Another repetitive trauma can be from using a cane, crutches or pressure from using a splint. The most significant symptom at this level is weakness of the pinch power of the thumb and sensory loss occurs in the ring and small fingers.

L. ANTERIOR INTEROSSEOUS (PRONATOR TERES SYNDROME)

This syndrome can occur due to compression of the median nerve as it passes through the heads of the pronator teres muscles.

Etiology: Most common is direct trauma by a heavy blow to the upper forearm. Reactive swelling of the muscles in this area can be causative by compressing the median nerve against the sublimis edge. Occult trauma such as forceful repeated pronation accompanying forceful finger flexion causes a hypertrophy of the pronator muscle which tautens the sublimis edge and compresses the median nerve.

Sensory loss is over the radial side of the palm and palmar side of the thumb, index, middle and radial half of the ring finger.

Motor findings include inability to pronate the wrist, and loss of flexion of the IP joint of the thumb. In the Pronator Teres Syndrome, thenar atrophy is not as severe as in carpal tunnel syndrome. Such cases are usually given a schedule loss of use of the hand depending upon motor and sensory deficits.

L.(A) POSTERIOR INTEROSSEOUS

Posterior Interosseous nerve syndrome is a neuropathy of the deep muscular branch of the radial nerve. This usually manifests into two distinct entities: a motor syndrome, and a rarer entity, a pain syndrome. The pain syndrome is also called radial tunnel syndrome, resistant tennis elbow and clinically resembles a painful tennis elbow.

Etiology: The posterior interosseous nerve can be compressed by a tumor, ganglia, elbow synovitis or trauma. The traumatic injury may be a dislocation of the elbow, fracture of the ulna with dislocation of the radial head and radial head fractures. The posterior interosseous nerve can be injured by the compression plates used in the open reduction of fractures of the proximal radius. Compression of the nerve usually occurs at the point of entrance to the supinator muscle under the arcade of Frohse.

The clinical features of the posterior interosseous nerve motor syndrome may manifest with complete or partial weakness of the muscles

supplied by the nerve, extensor carpi radialis, extensor digitorum communis, extensor indicis propius, abductor policis longus and brevis and extensor policis longus. There is usually weakness in extension of the wrist and is deviated radially. There will be weakness of the extension of the MCP joints of the fingers and thumb and weakness of abduction of the thumb radially.

Any residual neurological and functional deficit are the criteria for schedule loss of use and is usually given to the hands. If the examiner finds a defect of the elbow joint that is causally related, the schedule loss of use is given to the arms.

M. LATERAL FEMORAL CUTANEOUS NERVE (MERALGIA PARESTHETICA)

The lateral femoral cutaneous nerve is vulnerable to an entrapment neuropathy in the region of the anterior superior spine where it passes through the lateral end of the inguinal ligament. This is the binding point of the nerve. If the extremity is adducted, the nerve is tensed against the entrapment point. The ensuing neuropathy causes the burning type pain over the anterolateral thigh with some hypaesthesia.

Etiology: It can follow a direct trauma to the area or a fracture of the anterior ilium. It can be caused by a shortened limb (i.e., post hip replacement) with a pelvic tilt. This causes adduction of the opposite hip stretching the deep fascia and nerve against the entrapment point. Secretaries sitting with legs crossed for prolonged periods of time may not have the same symptoms.

Meralgia Paresthetica is uncommon in workers' compensation. It is usually amenable for a schedule loss of use of the leg if there is a residual sensory deficit.

N. TARSAL TUNNEL

SYNDROME (POSTERIOR TIBIAL ENTRAPMENT)

It occurs behind and immediately below the medial malleolus. In this area the nerve is accompanied by tendons of the posterior tibialis, flexor hallucis longus and flexor digitorum longus muscles. The laciniate ligament roofs over the structure and converts the passageway into an osseofibrous tunnel. Tenosynovitis in this area can cause swelling acting as a space occupying lesion within the tarsal tunnel compressing the nerve.

Signs and symptoms include burning pain involving the toes and sole of the foot. If calcaneal branches are involved, pain is primarily in the heel. Pain may be referred along the sciatic axis to the buttock. History may furnish relevant trauma. There may be impairment of the flexion at the MTP joints of all the toes.

Pressure over the nerve may cause pain into the distribution of the posterior tibial nerve. Holding the heel in various positions may alleviate symptoms. Treatment is severing the flexor retinaculum.

Tarsal Tunnel Syndrome is quite common in Workers' Compensation. With or without surgery it is amenable for schedule loss of use of the foot depending upon residual defects of motion and neurological deficit.

O. PLANTAR (MORTON'S METATARSALGIA)

Entrapment is produced by hyperextension at the metatarsophalangeal joints in the foot. It produces pain most frequently between the 3rd and 4th toes (Morton's neuroma). There is anesthesia at the tip of the toes, also tenderness of the nerve (Interdigital) as it crosses the deep transverse ligament. These nerves come up from the sole of the foot to reach the more dorsal termination on

the toes. These nerves are triggered against the transverse ligament when the toes are hyperextended at the MTP joints. Initially there is radiating pain into the 3rd and 4th toes only while walking, then pain recurs spontaneously at night.

Morton's metatarsalgia is usually given a schedule loss of use of the foot.

P. COMPLICATIONS OF PLEXUS AND PERIPHERAL NERVE INJURY

Pain as in sensory radiculopathies may be referred to the sclerotome (i.e., muscle, fascia, periosteum and bone) and leads to an immobilization of the secondary changes in a joint; for example, a frozen shoulder may complicate cervical spondylosis.

Q. CAUSALGIA

Injuries to certain nerves, particularly partial injury of the median and sciatic nerve or its tibial branches or of the brachial plexus, give rise, either immediately or after a few weeks, to a condition of burning pain or causalgia.

In severe cases, the claimant may be crippled and demoralized (temporary total disability). Trophic changes are common: red and glossy skin, excessive or diminished sweating, and osteoporosis. The joints may undergo ankylosis and the muscle may waste. The mechanism of causalgia is unknown, although it most often occurs in partially injured nerves suggesting a transient demyelination between the nerve fibers wherein the short circuiting sympathetic impulses activate pain fibers. Psychogenic factors are important. Neurolysis at the site of the injury may help or a proximal sympathetic block may be effective. However, in long standing cases, even posterior root section or spinothalamic tractotomy

may be ineffective. The limb must be kept mobile to prevent contracture and deformity. A delay in surgery is generally advisable in peripheral nerve and plexus injuries that are closed. As with most nerve lesions, claimant should be observed for at least a two year period.

Reflex sympathetic dystrophy at times is considered a separate entity having more psychogenic factors than causalgia. The term is used to describe a latent pain syndrome, not related to nerve damage. The etiology is very uncertain and the disorder affects skin, muscles, tendons, blood vessels and bones. This may be seen after fractures and this can also occur after myocardial infarction. Commonly seen are dysesthesia hyperesthesia and hyperpathia. Cases of causalgia and reflex sympathetic dystrophy may require referral to a pain clinic. When modalities of treatment fail and symptoms persist, especially pain, then consider classification.

V. LESS COMMON WORK RELATED CONDITIONS AND DISORDERS

A. MEDICAL DISORDERS

The above work-related medical conditions are drawn from review of medical records, consultant reports and physical examination findings. If claimant has finished treatment, is completely asymptomatic and has no physical findings, one may be given no disability. Symptomatic disabling cases may be given permanent partial or total disability depending on severity of symptoms, clinical findings and functional impairment.

1. WORK RELATED DERMATITIS

1. The Workers' Compensation Law Judge must establish accident or occupational disease, notice and causal relation.
2. There must be a history of exposure to irritants and chemicals in the place of employment.
3. The Medical Examiner must review medical records, dermatologist reports, diagnostic testing, response to medication and treatment.
4. The examining physician must perform a thorough examination of affected areas and describe active and residual lesions.

2. CAUSALLY RELATED INFECTIOUS DISEASES

1. Herpes simplex, autoimmune deficiency syndrome, infectious and viral hepatitis

are the most common infectious diseases seen as work related. Such cases often seen among health care providers and ancillary workers.

2. There is usually a history of exposure.
3. It is important to review medical records, hospitalization and diagnostic tests (i.e., blood studies). If needed, request an infectious disease consultant opinion.
4. The examining physician must consider the period of time which has elapsed since the claimant's exposure as well as the severity of the condition.

3. WORK RELATED POST TRAUMATIC NEUROSI; POST TRAUMATIC STRESS DISORDER AND OTHER CAUSALLY RELATED PSYCHIATRIC CONDITIONS

Such cases always have neuro-psychiatric and psychological evaluations and opinions in the file. There are also court hearing testimonies of psychiatrists and psychologists on record.

SURGICAL DISORDERS

A. HERNIA

1. Accident or occupational disease, notice and causal relation must be established by the Workers' Compensation Law Judge.
2. There should be a history of trauma, lifting or pulling.
3. The examining physician must review the medical records, surgeon's reports, operative reports and physical exam. All hernias which remain symptomatic following repair or multiple repairs are considered partial disabilities for a period

of one to two years. Hernias, recurrent or not, which are symptomatic and require wearing a truss, may after two years be classified permanent partial disability. Cases that are successfully repaired and asymptomatic are given no disability.

B. CAUSALLY RELATED SURGICAL EXCISION OF VITAL ORGANS

Surgical excision (partial or total) of vital organs, usually following a history of trauma, such as excision of a spleen, removal of one kidney, partial excision of the liver, partial excision of lung tissue and /or lobectomy, and orchiectomy are classified permanent partial disability.

C. FACIAL SCARS AND DISFIGUREMENT

1. Permanent scars and disfigurement of the face and neck are usually evaluated one year post-injury and/or one year after the last surgical procedure was performed.
2. Scars and disfigurement involving the neck are limited to the region above the clavicle.
3. The scar and disfigurement should be described accurately, using such parameters as length, width, color, contour, and exact location.
4. Specific disfigurements of the eye, ear, nose and mouth are also to be noted.
 - a. Common disfigurements of the eye include corneal scarring; defects of the iris and in some instances total loss of the eye with use of a prosthesis.
 - b. Common disfigurements of the nose include nasal septal deviation, enlargement and tissue loss.

- c. Common disfigurements of the lips include loss of soft tissue, enlargement, and alteration of normal contour of the lips.
- d. Common disfigurements of the ear include loss of tissue and alteration of normal contour of the ear.
- e. If teeth are damaged, the dentist's report should be consulted.

VI. RESPIRATORY DISEASES, CARDIOVASCULAR DISEASES AND VASCULAR DISEASES OF THE EXTREMITIES

The examining physician should be familiar with the pathophysiology of the respiratory and cardiovascular system.

A. EVALUATION PROCESS

The evaluation process of work-related respiratory and cardiovascular diseases and for vascular diseases of the extremities involves the following:

1. ANCR and/or ODNCR has to be established by the Workers' Compensation Law Judge.
2. Review the case folder, medical records, emergency room reports, and reports of hospitalization, and cardiac care. Note cardiology and pulmonology consultation and the vascular surgeon's reports. Review diagnostic testing:
 - a. EKG, enzyme studies, echocardiogram, isotope, hemodynamics, angiography, and scan

- b. chest X-ray, pulmonary function tests, and ABG's
 - c. Doppler studies, phlebogram and arteriograms.
3. Review past history, pre-existing medical conditions such as diabetes mellitus and hypertension, as well as habits such as alcohol, tobacco, and drugs. Note history of exposure to fiber, dust, and/or irritating materials.
4. Physical Examination: Note general appearance, weight, habitus, type of breathing, blood pressure, pulse rate, heart sounds, lung sounds, signs of heart failure, and edema.
5. Review claimant's treatment: Response to medication, need for oxygen inhalation and surgical procedures performed.
6. Assess and review functional capabilities, physical restriction, level of activity causing symptoms, and ability to perform activity of daily living.
7. Determine partial or total disability following the evaluation process. Permanency is considered if two or more years has elapsed since the reported date of accident or exposure. A claimant with respiratory and/or cardiovascular diseases may be determined to have no work-related disability or a work related disability in one of the following categories:

No Disability

Partial Disability

Permanent Partial Temporary Total

Permanent Total

B. RESPIRATORY DISEASES

1. HISTORY

Consider the claimant's history of exposure (both occupational and environmental) to:

1. Causative agent such as chemicals, gases, vapors, fumes and tobacco, etc.
2. Industrial dust, such as asbestos, silica, wood-working dust, amosite, procidolite, aluminum, and disatomaceous earths, etc.

2. CLINICAL EVALUATION

Clinical evaluation of respiratory diseases encompasses key functional factors that have to be taken into consideration.

Dyspnea is a major criterion in the assessment of the severity of respiratory impairment.

Mild - walking fast on level or slight hill

Moderate - level ground

Severe - level and at rest

Cough and sputum production. Consider volume, color, odor, consistency, amount and frequency.

Wheezing is common. Careful history taking and review of medical

reports would guide the examining physician to exclude other causes such as, airway obstruction, asthma, foreign bodies, tumors and congestive heart failure.

3. PHYSICAL EXAMINATION

Physical examination of a claimant with respiratory disease should include evaluation of the following parameters:

BP - P - R

Movement of the chest En masse

Accessory musculature

Intercostal muscle reaction

Paradox/Diaphragmatic motion

Description of breathing-

Tachypnea Cyanosis/clubbing of the extremities

Lung sounds such as wheezing,

rhonchi, rales

Cor Pulmonale

Neck veins and distention

Peripheral adema

4. Diagnostic Testing

Diagnostic testing reports should be reviewed and should correlate with clinical manifestations and physical findings:

Chest X-ray - no definitive correlation between ability to work and x-ray findings.

Lung Scan

Blood studies and other lab tests, i.e., sputum smear culture.

Biopsy

Pulmonary Function Tests/Simple

spirometry: Result of a series of

pulmonary function tests is

extremely important in the diagnosis and

prognosis of respiratory diseases. It is

also a reliable tool in determining the

severity of respiratory impairment. Listed

below are key parameters that should be

considered in the review of medical records.

Correlation between work and FEV₁
< 1L - Question ability to work

When FEV₁/FVC ratio < 40%
Question longevity

Copies of tracings

Total height and weight - (arm span)

Diffusing capacity of CO (D_{co})

Measured exercise capacity

VO₂ in ml/(kg-min)

FVC equals forced vital capacity

FEV₁ ratio equals forced expiratory volume in first second

D_{co} equals diffusing capacity of carbon monoxide; amount of CO diffusing across alveolar capillary membrane in specific time

VO₂ max equals measured exercise capacity

MET = unit equal to 3.5 ml O₂ (kg-min)

Pa O₂ = tension arterial O₂

a/c = alveolar capillary

Arterial Blood Gases (ABG's)

Pa O₂ < 60% Severe

Pulmonary hypertension, Cor Pulmonale

5. CRITERIA FOR EVALUATING DEGREE OF DISABILITY AS RELATED TO RESPIRATORY DISEASES

Listed below are the criteria for determining the degree of disability of respiratory diseases, set up in categories of Mild, Moderate, Marked, Partial and Total.

Accepted Normal Values For Pulmonary Function Tests Are Set Forth In The *AMA Guides to Evaluation of Permanent Impairment*.

Definition of Permanent Partial Disability Mild

1. The claimant has a causally related respiratory disorder and/or impairment with pulmonologist documentation and an appropriate diagnostic test.
2. The claimant is asymptomatic and stable, takes little or no medication and has complaints.
3. The claimant is able to perform usual tasks and activities of daily living without dyspnea. If dyspnea occurs, it is consistent with the circumstances of activity.
4. The claimant's medical record must contain a test of pulmonary function taken within a six-month period. Forced spirometric measurements FEV₁/FVC ratio is 70% to 85% of predicted "normal."

Moderate

1. The claimant has a causally related respiratory disorder and/or impairment with pulmonologist documentation and an appropriate diagnostic test.
2. The claimant may have complaints and episodes of exacerbation of respiratory symptoms. He/she takes medication to control symptoms.
3. Dyspnea occurs during performance of the usual activities of daily living. It does not occur at rest.
4. Pulmonary function test with forced spirometry measurements FEV₁/FVC ratio 50% to 70% of predicted "normal" taken within a six-month period.

Marked

1. The claimant has a causally related respiratory disorder and/or impairment with pulmonologist documentation and an appropriate diagnostic test.
2. The claimant has multiple complaints such as chronic cough, shortness of breath and frequent exacerbation of respiratory symptoms. Takes medications regularly to control symptoms.
3. Dyspnea occurs on minimal physical exertion such as usual housework and activities of daily living, walking one block on level ground and/or climbing one flight of stairs.
4. Pulmonary function test with forced spirometry measurements FEV₁/FVC ratio is 40% to 50% of

predicted "normal." Diffusing capacity of carbon monoxide (D_{co}) = 40% or less of predicted "normal." Both of the above taken within six month period.

Permanent Total Disability

1. The claimant has a causally related respiratory disorder and/or impairment with a pulmonologist documentation and an appropriate diagnostic test.
2. The claimant is symptomatic, under active respiratory care, may be confined to a chair or bed, may be O₂ dependent, has multiple complaints and needs medication to control symptoms.
3. There are positive findings on physical examination such as cyanosis, clubbing of the digits and positive lung findings.
4. Pulmonary function test with forced spirometry measurements FEV₁/FVC ratio is 40% or less of predicted "normal." Diffusing capacity of carbon monoxide (D_{co}) = 20% or less of predicted "normal." Both of the above taken within six month period.

C. CARDIOVASCULAR DISEASES

1. MEDICAL EVALUATION OF CARDIOVASCULAR CASES

The most common work-related cardiovascular disease is myocardial infarction. Other cardiovascular diseases are seldom claimed to be work related and may be found to be preexisting conditions, i.e., hypertensive cardiovascular disease, coronary artery disease, valvular heart disease cardiomyopathies, etc.

Summary of the medical evaluation of cardiovascular cases:

1. Analysis of findings

2. Symptomatic limitations

3. Objective data:

- a. Exercise testing one MET = 3.5 ml O₂ (kg-min)
- b. Treadmill
- c. Ability to perform activities of daily living

2. EVALUATION CRITERIA FOR CARDIOVASCULAR DISEASES

The following are criteria that may be used for the evaluation of degree of disability in cases involving cardiovascular diseases.

Permanent Partial Disability

Mild

- 1. The claimant has a history of documented myocardial infarction myocardial ischemia and/or angina that occurred at least one year before the time of evaluation.
- 2. The medical file has all the appropriate diagnostic studies such as positive EKG and cardiac enzymes.
- 3. The claimant is stable, recovered and asymptomatic and requires very little or no medication.

- 4. There are no physical findings of congestive heart failure.
- 5. There are no reported arrhythmias.
- 6. The claimant is performing his/her usual tasks, recreational activities and activities of daily living without complaints or symptoms.

Moderate

- 1. The claimant has a history of documented myocardial infarction, myocardial ischemia and/or angina.
- 2. Appropriate diagnostic tests are positive.
- 3. The claimant may have history of coronary artery surgery or angioplasty which took place at least one year prior to final evaluation of the claimant.
- 4. The claimant is asymptomatic at rest and responds well to medication.
- 5. There are no physical findings of congestive heart failure.
- 6. There are no bouts of angina.
- 7. There are no reported arrhythmias
- 8. The claimant performs his/her usual tasks and activities of daily living without symptoms.
- 9. The claimant becomes symptomatic with moderate to heavy exertion.

Marked

- 1. The claimant has a history of documented myocardial infarction, myocardial ischemia and/or angina.

2. Appropriate diagnostic tests are positive.
3. There is a history of coronary artery surgery or angioplasty. The claimant continues to require cardiac care.
4. There are complaints of recurrent angina and/or shortness of breath on mild exertion.
5. The claimant needs medication to control angina, congestive heart failure and/or arrhythmias.
6. The claimant may have physical findings of congestive heart failure and/or arrhythmias.
7. The claimant becomes symptomatic when walking one block and/or climbing one flight of stairs.

Permanent Total Disability

1. There is a history of documented myocardial infarction, myocardial ischemia and/or unstable angina.
2. Appropriate diagnostic tests are positive.
3. There is a history of coronary artery surgery or angioplasty. Claimant is partially recovered or may be failed and required continuous coronary care.
4. The claimant requires medication to control complaints and/or symptoms.
5. The claimant has recurrent episodes of angina and/or shortness of breath at rest and/or on minimal exertion or activity.

6. The claimant may not be responding well to treatment and/or may be using oxygen inhalation.
7. The claimant may or may not have physical signs of congestive heart failure and/or arrhythmias.
8. The claimant is unable to perform usual tasks and may need assistance in the activities of daily living.

D. VASCULAR DISEASE THE EXTREMITIES

Listed below are clinical findings that an examining physician should consider in the vascular examination of the extremities:

1. Claudication
2. Pain at rest
3. Trophic changes
4. Ulceration
5. Gangrene
6. Loss of extremity
7. Raynaud's
8. Disease of veins
9. Disorders of the Lymphatics

Vascular diseases of the extremities are rarely seen as work-related. If seen, they are almost always preexisting conditions and aggravated by an injury or trauma to the extremity. The examining physician's guide in deciding whether to give a schedule loss of use or classification depends upon the severity of symptoms, physical findings and response to medical and surgical treatment. Amputation of an extremity with good result and no complications should be given a schedule loss of use. Cases with chronic ulcers, chronic phlebitis, stasis dermatitis, gangrene and osteomyelitis are classified permanent partial or total disability.

VII. VISUAL SYSTEM

INTRODUCTION

The purpose of this chapter is to provide criteria for use in evaluating permanent impairment resulting from dysfunction of the visual system, which consists of the eyes, ocular adnexa and the visual pathways. A method is provided for quantitating visual impairment resulting from a work-related injury. This can then be translated into a payment schedule.

The parameters for scheduling are: (1) loss of uncorrected or corrected visual acuity for objects at distance, (2) visual field loss and (3) diplopia. Evaluation of visual impairment is based on these three functions. Although they are not equally important, vision is imperfect without the coordinated function of all three.

Where there is a visible deformity related to the eye and face, this is scheduled on a per case basis.

The following equipment is necessary to test the functions of the eye:

1. Visual acuity test charts for distance vision; the Snellen test chart with letters

and numbers, the illiterate E chart, or Landolt's broken-ring chart is desirable.

2. Either a Goldmann type or automated perimeter where the extent of visual field is recorded in degrees.
3. Refraction equipment or report of a recent refraction or recently prescribed glasses.
4. A hand held light with a red glass.
5. A slit lamp.
6. An ophthalmoscope.

A. CRITERIA AND METHODS FOR EVALUATING PERMANENT IMPAIRMENT

1. CENTRAL VISUAL ACUITY

The chart or reflecting surface should not be dirty or discolored. The far test distance simulates infinity at 6 m (20 ft.) or at no less than 4 m (13 ft. 1 in.).

The central vision should be measured and recorded for distance with and without wearing conventional spectacles. The use of contact lens may further improve vision reduced by irregular astigmatism due to corneal injury or disease. In the absence of contraindications, if the patient is well adapted to contact lenses and wishes to wear them, correction by contact lenses is acceptable.

Visual acuity for distance should be recorded in the Snellen notation, using a fraction, in which the numerator is the test distance in feet or meters, and the denominator is the distance at which the smallest letter discriminated by the patient would subtend 5 minutes of arc, that is, the distance at which an eye with 20/20 vision would see that letter. The fraction notation is one of convenience that does not imply percentage of visual acuity.

The Procedure for determining the loss of central vision in one eye is as follows:

- (1) Measure and record best central visual acuity for distance with and without conventional corrective spectacles or contact lens.
- (2) Schedule according to the Table 1 for uncorrected or corrected visual loss (in the injured eye) whichever is greater.

**TABLE 1
SCHEDULE VISUAL LOSS**

Visual Acuity	Schedule %
20/20	0
20/20-1	5
20/20-2	7 1/2
20/20-3	10
20/20-4	15
20/25	20
20/25-1	22 1/2

20/25-2	25
20/30	33 1/3
20/30-1	35
20/30-2	37 1/2
20/30+1	30
20/30+2 or 3	27 1/2
20/40	50
20/40+2	45
20/40+3	40
20/40-1 or 2	52 1/2
20/40-3	55
20/50	60
20/60	65
20/70	70
20/70-1 or 20/70-2	75
Over 75% give 100%	

2. VISUAL FIELDS

The extent of the visual field is determined by using a perimetric method with a white target. If the Goldmann 30 cm. radius bowl perimeter is used, the III/4 e target in the kinetic mode should be employed.

3. DETERMINING LOSS OF VISUAL FIELD

The following steps are taken to determine the loss of visual field:

- (1) Plot the extent of the visual field on each of the eight principal meridians of a visual field chart (Figure 13).
- (2) Determine the percentage loss to schedule according to Table II.

4. DETERMINING SCHEDULE FOR DIPLOPIA

Do red glass test, charting magnitude of diplopia within 30 degree field and calculate according to Table III. Schedule to loss for the injured eye. Combine the percentage loss for diplopia with the schedule for central vision loss and visual field loss in the injured eye.

**TABLE II
VISUAL FIELD LOSS**

Loss of	Schedule-One Eye %
Upper	33 1/3
1/2 of Upper	16 2/3
Lower	66 2/3
1/2 of Lower	33 1/3

Also: Sum of 8 principal radii of peripheral field total 420. This is 100% industrial visual field efficiency.

To calculate: Add 8 principal meridians of patient's peripheral field (x)

x
-- = % Efficiency (y)
420

100 - y% = % Loss to schedule for eye

**TABLE III
DIPLOPIA
Consider for 30 degree field**

Diplopia In	Schedule-One-Eye%
Entire Upper Field	33 1/3
Half of Upper Field	16 2/3
Entire Lower Field	66 2/3
Half of Lower Field	33 1/3

Figure 13. Example of Perimetric Charts.

Note: Charts used to plot extent or outline of visual field along the eight principal meridians that are separated by 45 degree intervals.

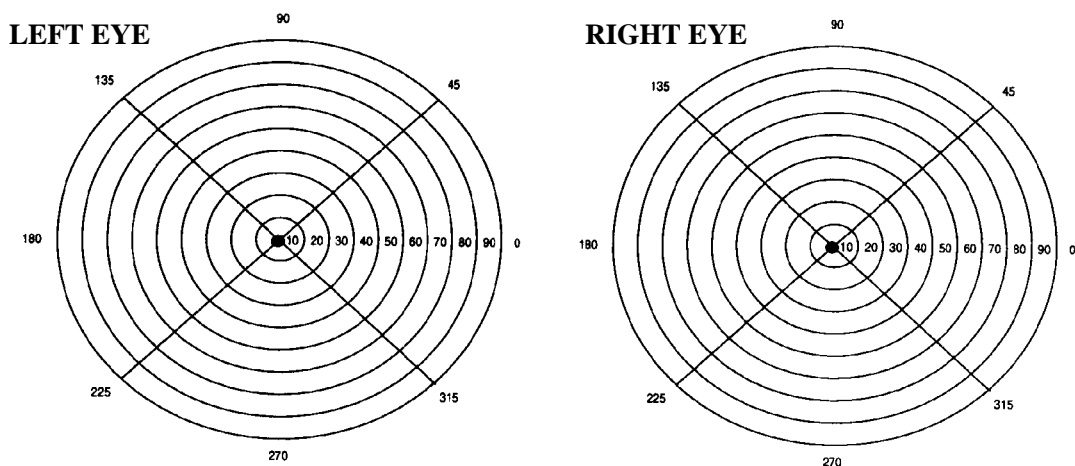

Note: Charts used to plot extent or outline of visual field along the eight principal meridians that are separated by 45 degree intervals.

VIII. LOSS OF HEARING

The waiting period for a worker to file a claim for a job-related hearing loss is three months from the date the worker leaves employment or is removed from exposure to harmful noise in the workplace (can be by way of effective protective devices). The last day of the three month period of removal is considered the worker's date of disablement.

A. OCCUPATIONAL LOSS OF HEARING

Under these standards which in effect measure the ability to hear normal speech, audiometric tone tests at varying intensity of sound are conducted at frequency levels of 500, 1000, 2000, 3000 Hertz (Hz).

Results at the four frequency levels are averaged and if the threshold necessary for the individual to hear sound is 25 decibels (dB) or less, no hearing impairment is considered to be present.

For every decibel that the hearing level of an ear exceeds 25 dB, hearing loss is calculated at 1 1/2 percent, up to 100 percent at 92 dB. Thus, if the worker's hearing level is 41 dB, he or she would have a hearing loss of 24 percent in that ear.

The percentage of hearing loss in the worker's better ear is multiplied by 5, and the resulting figure is added to the percentage of hearing loss in the worker's poorer ear. The total is divided by 6 and this represents the worker's overall percentage of hearing loss for which benefits are awarded.

B. TRAUMATIC LOSS OF HEARING

Traumatic Hearing Loss - May occur as a result of a blow to the head, a strong blast of air into the ear, etc.

A different method is used to determine the degree of hearing loss as a result of trauma than as a result of occupational disease.

The scale used to measure percentage is based upon 250 Cycles Per Second (CPS) to 4000 CPS.

The schedule for complete loss of hearing for both ears is 150 weeks, and the schedule for each ear is 60 weeks. The method used to compute the loss is to take the percentage of loss in each ear, total it, and then divide it by 2.

For example:

25% in right ear
40% in left ear
65% total loss

Divide 65% by 2, which equals 32 1/2%

APPENDIX I

USEFUL SOURCES OF REFERENCE

The following are some useful (and at times necessary) sources of reference for the evaluation of work-related disabilities:

1. The New York State Workers' Compensation Law, McKinney's Consolidated Laws of New York Annotated, (St. Paul, MN: West Publishing Co.).
2. The American Medical Association, Guides to the Evaluation of Permanent Impairment, (2nd ed. Chicago: American Medical Association, 1984). (Note: These guides provide useful reference material but are not applicable under the New York State Workers' Compensation Law.)
3. I. N. Rattner, MD., Injury Ratings, (New York: Crescent Publishing Company, 1970).
4. Stanley Hoppenfeld, MD., Physical Examination of the Spine and Extremities, (New York: Appleton - Century - Crofts, 1976).
5. Publications dealing with industrial and occupational medicine, the work place and the environment.

APPENDIX II

Table of Weeks by Percentage Loss of Use of Body Part:

	5%	7 1/2%	8 1/3%	10%	12 1/2%	15%	16 2/3%	20%	25%	30%	33 1/3%	35%	37 1/2%	40%	45%
Arm	15 3/5	23 2/5	26	31 1/5	39	46 4/5	52	62 1/5	78	93 3/5	104	109 1/5	117	124 4/5	140 2/3
Hand	12 1/5	18 3/10	20 1/3	24 2/5	30 1/2	36 3/5	40 2/3	48 4/5	61	73 1/5	81 1/3	85 2/8	91 1/2	97 3/5	109 4/5
Thumb	3 3/4	5 5/8		7 1/2	9 3/8	11 1/4	12 1/2	15	18 3/4	22 1/2	25	26 1/4	28 1/8	30	33 3/4
First Finger	2 3/10			4 3/5	5 3/4	6 4/5	7 2/3	9 1/5	11 1/2	13 4/5	15 1/3	16 1/10	17 1/4	18 2/5	20 7/10
Second Finger	1 1/2			3	3 3/4	4 1/2	5	6	7 1/2	9	10	10 1/2	11 1/4	12	13 1/2
Third Finger	1 1/4			2 1/2	3 1/8	3 3/4	4 1/6	5	6 1/4	7 1/2	8 1/3	8 3/4	9 3/8	10	11 1/4
Fourth Finger	3/4			1 1/2	1 7/8	2 1/4	2 1/2	3	3 3/4	4 1/2	5	5 2/5	5 5/8	6	6 3/4
Leg	14 2/5	21 3/5		28 4/5	36	43 1/5	48	57 3/5	72	86 2/5	96	100 4/5	108	115 1/5	129 3/5
Foot	10 1/4	15 3/8	17 1/2	20 1/2	25 3/8	30 3/4	34 1/6	41	51 1/4	61 1/2	68 1/3	71 3/4	76 7/8	82	92 1/4
Great Toe	1 9/10	2 17/20		3 4/5	4 3/4	5 7/10	6 1/3	7 3/5	9 1/2	11 2/5	12 2/3	13 3/10	14 1/4	15 1/5	17 1/10
Other Toes	4/5			1 3/5	2	2 2/5	2 2/3	3 1/5	4	4 4/5	5 1/3	5 3/5	6	6 2/5	7 1/5
Eye	8	12		16	20	24	26 2/3	32	40	48	53 1/3	56	60	64	72
	50%	55%	60%	62 1/2%	65%	66%	70%	75%	80%	83 1/3%	85%	87 1/2%	90%	95%	100%
Arm	156	171 3/5	187 1/5	195	202 4/5	208	218 2/5	234	249 3/5	260	265 1/5	273	280 4/5	296 2/3	312
Hand	122	134 1/5	146 2/5	152 1/2	158 3/5	162 2/3	170 4/5	183	195 1/5	203 1/3	207 2/5	213 1/2	219 3/5	231 4/5	244
Thumb	37 1/2	41 1/4	45	46 7/8	48 3/4	50	52 1/2	56 1/4	60	62 1/2	63 3/4	65 5/8	67 1/2	71 1/4	75
First	23	25 3/10	27 3/5	28 3/4	29 9/10	30 2/3	32 1/5	34 1/2	36 4/5	38 1/3	39 1/10	40 1/4	41 2/5	43 7/10	46
Second	15	16 1/2	18	18 3/4	19 1/2	20	21	22 1/2	24	25	25 1/2	26 1/4	27	28 1/2	30
Third	12 1/2	13 3/4	15	15 5/8	16 1/4	16 2/3	17 1/2	18 3/4	20	20 5/6	21 1/4	21 7/8	22 1/2	23 3/4	25
Fourth	7 1/2	8 1/4	9	9 3/8	9 3/4	10	10 1/2	11 1/4	12	12 3/4	13 1/8	13 1/2	14 1/4	14 1/4	15
Leg	144	158 2/5	172 4/5	180	187 1/5	192	201 3/5	216	230 2/5	240	244 4/5	252	259 1/5	273 3/5	288
Foot	102 1/2	112 3/4	123	128 1/8	133 1/4	136 2/3	143 1/2	153 3/4	164	170 5/6	174 1/4	179 3/8	184 1/2	194 3/4	205
Great Toe	19	20 9/10	22 4/5	23 3/4	24 7/10	25 1/3	26 3/5	28 1/2	30 2/5	31 2/3	32 3/10	33 1/4	34 1/5	36 1/10	38
Other Toes	8	8 4/5	9 3/5	10	10 2/5	10 2/3	11 1/5	12	12 4/5	13 1/3	13 3/5	14	14 2/5	15 1/5	16
Eye	80	88	96	100	104	106 2/3	112	120	128	133 1/3	136	140	144	152	160